



## OPERATOR'S MANUAL



MOBILE ELEVATING WORK PLATFORM  
**S1530E, S1930E, S2032E, S2046E,  
S2632E, S2646E, S3246E, S4046E, S4550E**

EN - 9831/3200 ISSUE 3 - 09/2017

THIS MANUAL SHOULD ALWAYS STAY WITH THE MACHINE





# OPERATOR'S MANUAL

MOBILE ELEVATING WORK PLATFORM  
**S1530E, S1930E, S2032E,  
S2046E, S2632E, S2646E,  
S3246E, S4046E, S4550E**

EN - 9831/3200 - ISSUE 3 - 09/2017

This manual contains original instructions, verified by the manufacturer (or their authorized representative).

Copyright 2017 © JCB SERVICE  
All rights reserved. No part of this publication may be reproduced, stored in a retrieval system, or transmitted in any form or by any other means, electronic, mechanical, photocopying or otherwise, without prior permission from JCB SERVICE.

[www.jcb.com](http://www.jcb.com)

## Foreword

### The Operator's Manual

 You and others can be killed or seriously injured if you operate or maintain the machine without first studying the Operator's Manual. You must understand and follow the instructions in the Operator's Manual. If you do not understand anything, ask your employer or JCB dealer to explain it.

Do not operate the machine without an Operator's Manual, or if there is anything on the machine you do not understand.

Treat the Operator's Manual as part of the machine. Keep it clean and in good condition. Replace the Operator's Manual immediately if it is lost, damaged or becomes unreadable.

### Machine Delivery and Installation

Even if you have operated this type of equipment before, it is very important that your new machines operations and functions are explained to you by a JCB Dealer Representative following delivery of your new machine.

Following the installation you will know how to gain maximum productivity and performance from your new product.

Please contact your local JCB dealer if the Installation Form (included in this manual) has not yet been completed with you.

Your local JCB Dealer is



---

Notes:

---

---

---

---

---

---

---

---

---

---

---

---



Contents	Page No.
<a href="#">Acronyms Glossary</a> .....	<a href="#">iv</a>
<b>Introduction</b>	
About this Manual	
Model and Serial Number .....	1
Using the Manual .....	1
Left-Hand Side, Right-Hand Side .....	1
Cross References .....	2
Location of Manual .....	2
Safety	
Safety - Yours and Others .....	3
Safety Warnings .....	3
General Safety .....	4
Clothing and Personal Protective Equipment (PPE) .....	4
<b>About the Product</b>	
Introduction	
General .....	5
Name and Address of the Manufacturer .....	5
Product Compliance .....	5
Description	
General .....	6
Intended Use .....	6
Log Moving/Object Handling .....	6
Danger Zone .....	6
Main Component Locations .....	7
Product and Component Identification	
Machine .....	9
Safety Labels	
General .....	10
Safety Label Identification .....	10
<b>Operation</b>	
Introduction	
General .....	15
Operating Safety	
General .....	16
Worksite Safety .....	17
Risk Assessment .....	17
Walk-Around Inspection	
General .....	19
Entering and Leaving the Operator Station	
General .....	20
Battery Isolator	
General .....	22
Stopping and Parking	
General .....	24
Getting the Machine Moving	
General .....	25
Slopes	
General .....	26



Driving on Slopes .....	26
Driving the Machine	
General .....	28
Operating Levers/Pedals	
Control Layouts .....	29
Working with the Platform	
General .....	32
Extending and Retracting the Platform .....	35
Folding and Unfolding the Guardrails .....	35
Moving a Disabled Machine	
General .....	37
Lifting the Machine	
General .....	39
Transporting the Machine	
General .....	41
Loading the Machine onto the Transporting Vehicle/Trailer .....	41
Operating Environment	
General .....	43
<b>Preservation and Storage</b>	
Storage	
General .....	45
Take out of Storage .....	45
<b>Maintenance</b>	
Introduction	
General .....	47
Owner/Operator Support .....	47
Service/Maintenance Agreements .....	48
Obtaining Spare Parts .....	48
Maintenance Safety	
General .....	49
Fluids and Lubricants .....	49
Batteries .....	51
Maintenance Schedules	
General .....	55
How to Use the Maintenance Schedules .....	55
Maintenance Intervals .....	55
Pre-start Cold Checks, Service Points and Fluid Levels .....	56
Functional Tests and Final Inspection .....	57
Maintenance Positions	
General .....	58
Service Points	
General .....	61
Access Apertures	
General .....	63
Battery Cover .....	63
Hydraulic Compartment Cover .....	63
Body and Framework	
General .....	65
Safety Equipment	
Check (Operation) .....	66



---

Brakes	
Park Brake .....	68
Steering System	
General .....	69
Tyres	
General .....	70
Hydraulic System	
General .....	71
Oil .....	74
Electrical System	
General .....	75
Battery .....	75
Battery Isolator .....	80
Fuses .....	80
Relays .....	81
<b>Technical Data</b>	
Introduction	
General .....	83
Static Dimensions	
Dimensions .....	84
Weights .....	87
Performance Dimensions	
Driving Performance .....	90
Noise Emissions	
Noise Data .....	94
Vibration Emissions	
Vibration Data .....	95
Fluids, Lubricants and Capacities	
General .....	96
Electrical System	
General .....	97
Fuses .....	97
Hydraulic System	
General .....	99
Wheels and Tyres	
General .....	100
Fault-Finding	
General .....	101
Declaration of Conformity	
General .....	103
Data .....	103
Warranty Information	
Service Record Sheet .....	105



**Acronyms Glossary**

AC	Alternating Current
LCD	Liquid Crystal Display
LED	Light Emitting Diode
MECU	Machine Electronic Control Unit
PPE	Personal Protective Equipment
RCBO	Residual current Circuit Breaker with Over current protection
USB	Universal Serial Bus



# Introduction

## About this Manual

### Model and Serial Number

This manual provides information for the following model(s) in the JCB machine range:

Model	From:	To:
S1530E	2532501	2537500
	2671002	2672000
S1930E	2532501	2537500
	2671002	2672000
S2032E	2532501	2537500
	2671002	2672000
S2046E	2532501	2537500
	2671002	2672000
S2632E	2532501	2537500
	2671002	2672000
S2646E	2532501	2537500
	2671002	2672000
S3246E	2532501	2537500
S4046E	2532501	2537500
S4550E	2533185	2537500

### Using the Manual

This operator's manual is arranged to give you a good understanding of the machine and its safe operation. It also contains maintenance and technical data.

Read this manual from the front to the back before you use the machine for the first time, even if you have used machines of a similar/same type before as the technical specification, systems and controls of the machine may have changed. Particular attention must be given to all the safety aspects of operating and maintaining the machine.

If there is anything you are not sure about, ask your JCB dealer or employer. Do not guess, you or others could be killed or seriously injured.

The general and specific warnings in this section are repeated throughout the manual. Read all the safety statements regularly, so you do not forget them. Remember that the best operators are the safest operators.

The illustrations in this manual are for guidance only. Where the machines are different, the text and or the illustration will specify.

The manufacturer's policy is one of continuous improvement. The right to change the specification of the machine without notice is reserved. No responsibility will be accepted for discrepancies which may occur between specifications of the machine and the descriptions contained in this manual.

All of the optional equipment included in this manual may not be available in all territories

### Left-Hand Side, Right-Hand Side

In this manual, 'left' and 'right' mean your left and right when you are stood in the platform facing the operator's manual storage case.

Figure 1.  
A

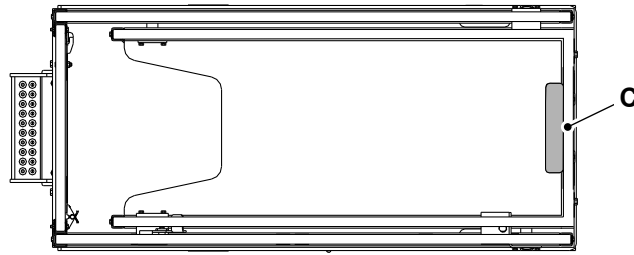

B

A Left

B Right

C Operator's manual storage case

## Cross References

In this manual, cross references are made by presenting the subject title in blue (electronic copy only). The number of the page upon which the subject begins is indicated within the brackets. For example: [Refer to: Cross References \(Page 2\)](#).

## Location of Manual

The operator's manual is located in a storage case at one end of the platform. The manual should always be returned to its case after use. [Refer to: Main Component Locations \(Page 7\)](#).

## Safety

### Safety - Yours and Others

All machinery can be hazardous. When a machine is correctly operated and maintained, it is a safe machine to work with. When it is carelessly operated or poorly maintained it can become a danger to you (the operator) and others.

In this manual and on the machine you will find warning messages, read and understand them. They inform you of potential hazards and how to avoid them. If you do not fully understand the warning messages, ask your employer or JCB dealer to explain them.

Safety is not just a matter of responding to the warnings. All the time you are working on or with the machine you must be thinking of what hazards there might be and how to avoid them.

Do not work with the machine until you are sure that you can control it.

Do not start any work until you are sure that you and those around you will be safe.

If you are not sure of anything, about the machine or the work, ask someone who knows. Do not assume anything.

Remember:

- Be careful
- Be alert
- Be safe.

### Safety Warnings

In this manual and on the machine, there are safety notices. Each notice starts with a signal word. The signal word meanings are given below.

The signal word 'DANGER' indicates a hazardous situation which, if not avoided, will result in death or serious injury.

The signal word 'WARNING' indicates a hazardous situation which, if not avoided, could result in death or serious injury.

The signal word 'CAUTION' indicates a hazardous situation which, if not avoided, could result in minor or moderate injury.

The signal word 'Notice' indicates a hazardous situation which, if not avoided, could result in machine damage.

The safety alert system (shown) also helps to identify important safety messages in this manual and on the machine. When you see this symbol, be alert, your safety is involved, carefully read the message that follows, and inform other operators.

**Figure 2. The safety alert system**



## **General Safety**

### **Training**

To operate the machine safely you must know the machine and have the skill to use it. You must abide by all relevant laws, health and safety regulations that apply to the country you are operating in. The operator's manual instructs you on the machine, its controls and its safe operation; it is not a training manual. If you are a new operator, get yourself trained in the skills of using a machine before trying to work with it. If you don't, you will not do your job well, and you will be a danger to yourself and others. In some markets and for work on certain jobsites you may be required to have been trained and assessed in accordance with an operator competence scheme. Make sure that you and your machine comply with relevant local laws and jobsite requirements - it is your responsibility.

### **Care and Alertness**

All the time you are working with or on the machine, take care and stay alert. Always be careful. Always be alert for hazards.

### **Clothing**

You can be injured if you do not wear the correct clothing. Loose clothing can get caught in the machinery. Keep cuffs fastened. Do not wear a necktie or scarf. Keep long hair restrained. Remove rings, watches and personal jewellery.

### **Alcohol and Drugs**

It is extremely dangerous to operate machinery when under the influence of alcohol or drugs. Do not consume alcoholic drinks or take drugs before or while operating the machine or attachments. Be aware of medicines which can cause drowsiness.

### **Feeling Unwell**

Do not attempt to operate the machine if you are feeling unwell. By doing so you could be a danger to yourself and those you work with.

### **Mobile Phones**

Switch off your mobile phone before entering an area with a potentially explosive atmosphere. Sparks in such an area could cause an explosion or fire resulting in death or serious injury.

### **Lifting Equipment**

You can be injured if you use incorrect or faulty lifting equipment. You must identify the weight of the item to be lifted then choose lifting equipment that is strong enough and suitable for the job. Make sure that lifting equipment is in good condition and complies with all local regulations.

### **Raised Machine**

Never position yourself or any part of your body inside the raised scissor pack which is not correctly supported. If the machine moves unexpectedly you could become trapped and suffer serious injury or be killed.

### **Lightning**

Lightning can kill you. Do not use the machine if there is lightning in your area.

### **Machine Modifications**

This machine is manufactured in compliance with prevailing legislative requirements. It must not be altered in any way which could affect or invalidate its compliance. For advice consult your JCB dealer.

## **Clothing and Personal Protective Equipment (PPE)**

Do not wear loose clothing or jewellery that can get caught on controls or moving parts. Wear protective clothing and personal safety equipment issued or called for by the job conditions, local regulations or as specified by your employer.

---

# About the Product

## Introduction

### General

Before you start using the machine, you must know how the machine operates. Use this part of the manual to identify each control lever, switch, gauge, button and pedal. Do not guess, if there is anything you do not understand, ask your JCB dealer.

### Name and Address of the Manufacturer

JCB Access Limited, Lakeside Works, Rocester, Uttoxeter, United Kingdom, ST14 5JP

### Product Compliance

Your JCB product was designed to comply with the laws and regulations applicable at the time of its manufacture for the market in which it was first sold. In many markets, laws and regulations exist that require the owner to maintain the product at a level of compliance relevant to the product when first produced. Even in the absence of defined requirements for the product owner, JCB recommend that the product compliance be maintained to ensure safety of the operator and exposed persons and to ensure the correct environmental performance. Your product must not be altered in any way which could affect or invalidate any of these requirements. For advice consult your JCB dealer.

For its compliance as a new product, your JCB and some of its components may bear approval numbers and marking's, and may have been supplied with a Declaration/Certificate of Conformity. These marking's and documents are relevant only for the country/region in which the product was first sold to the extent that the laws and regulations required them.

Re-sales and import/export of products across territories with different laws and regulations can cause new requirements to become relevant for which the product was not originally designed or specified. In some cases, pre owned products irrespective of their age are considered new for the purposes of compliance and may be required to meet the latest requirements which could present an insurmountable barrier to their sale/use.

Despite the presence of any compliance related marking's on the product and components, you should not assume that compliance in a new market will be possible. In many cases it is the person responsible for import of a pre owned product into a market that becomes responsible for compliance and who is also considered the manufacturer.

JCB may be unable to support any product compliance related enquiry for a product which has been moved out of the legislative country/region where it was first sold, and in particular where a product specification change or additional certification would have been required in order for the product to be in compliance.

---

## Description

### General

This machine is a self propelled aerial work platform on the top of an elevating scissor arm mechanism.

### Intended Use

The machine is intended to lift the personnel with their tools and position them at a level of working height. The machine can be used to reach areas located above machinery or equipment positioned at ground level by use of the extending platform.

The machine is intended to be used in normal conditions for the applications and in the environmental conditions as described in this manual. Use in any other way not described in the manual is considered contrary to intended use of this machine.

The machine is not intended for use in mining and quarrying applications, in demolition activities, forestry, any use underground, or in any kind of explosive atmosphere. This is not an exhaustive list. For any activity not described here, it is recommended that a risk assessment must be done prior to operation.

If the machine is to be used in applications where there is a high silica concentration, risk due to materials containing asbestos or similar hazards, additional protective measures such as the use of PPE (Personal Protective Equipment) may be required.

The machine should not be operated by any person who does not have an appropriate level of qualification, training or experience of use of this type of machine.

Prior to use of the machine, its suitability (size, performance, specification etc.) should be considered with regards to the intended application and any relevant hazards that may exist. Contact your JCB dealer for support in determining the appropriate JCB machine, attachment and any optional equipment that is suitable for the application and environment.

### Log Moving/Object Handling

Do not use the machine to move or handle logs or other objects. You could cause serious injury to yourself and damage to the machine. Do not use the machine as a crane. Do not overload the platform with tools or equipment. [Refer to: Technical Data \(Page 83\)](#). For more information, contact your JCB dealer.

### Danger Zone

The danger zone is any zone within and/or around the machinery in which a person is subject to a risk to their health or safety. During operation of the machine, keep all persons out of the danger zone. Persons in the danger zone could be injured.

Before you do a maintenance task, make the product safe. [Refer to: Maintenance Positions \(Page 58\)](#).

## Main Component Locations

Figure 3.

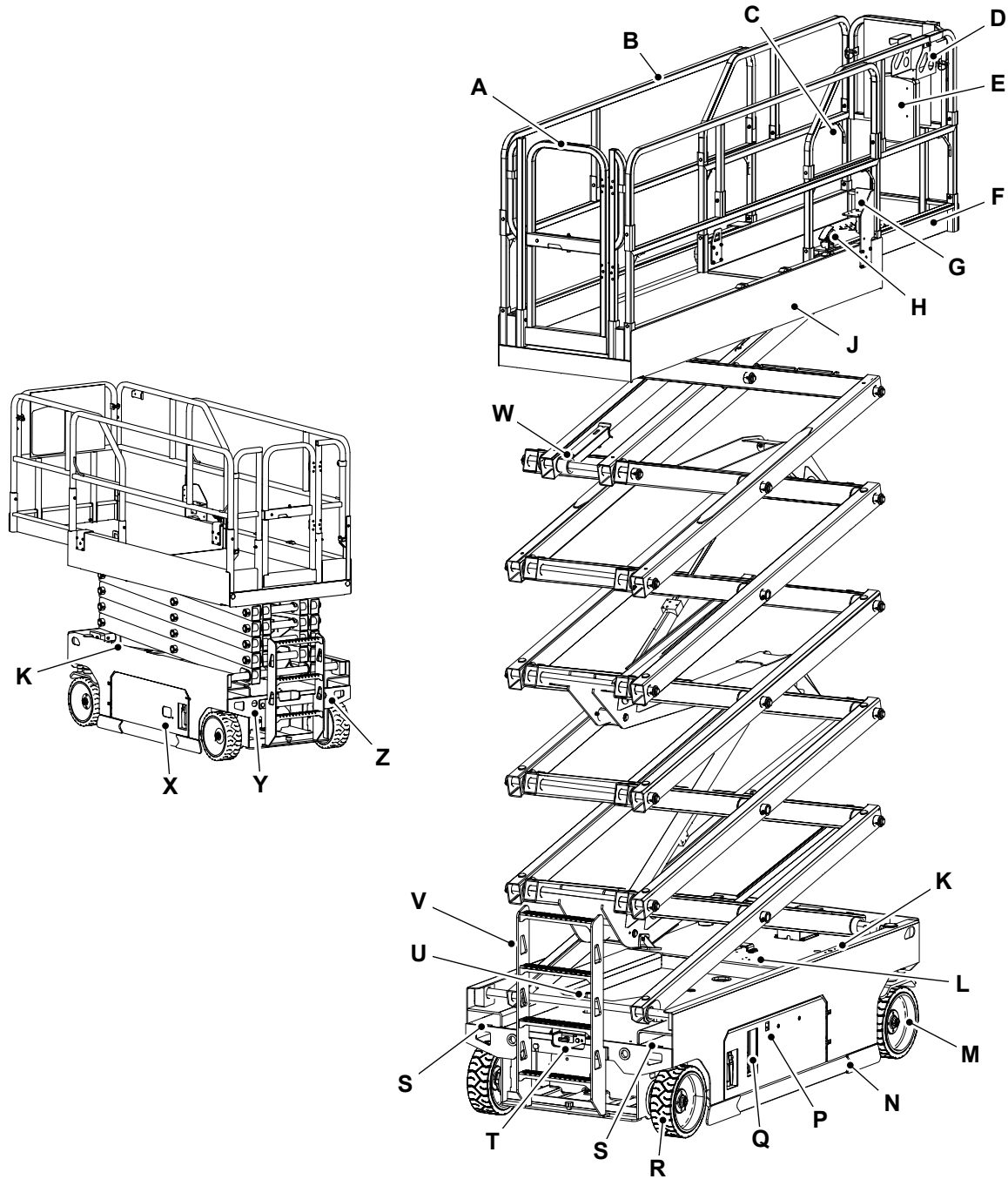

- A Gate
- C Harness fastening point
- E Operator's Manual
- G AC (Alternating Current) Power socket (option)
- J Main platform
- L Tilt sensor
- N Pot hole protection plate
- Q Ground controller
- S Lift point/forklift position
- U Pot hole activation plungers
- W Safety strut

- B Guardrail
- D Platform control panel
- F Platform extension
- H Extension platform pedal
- K Warning lights
- M Front wheel (steering)
- P MECU (Machine Electronic Control Unit) display
- R Rear wheel
- T Manual release valve and emergency lowering handle
- V Ladder
- X Battery charger



**Y** Charging plug

**Z** Power to platform plug



# Product and Component Identification

## Machine

Your machine has an identification plate as shown. Refer to Figure 4.

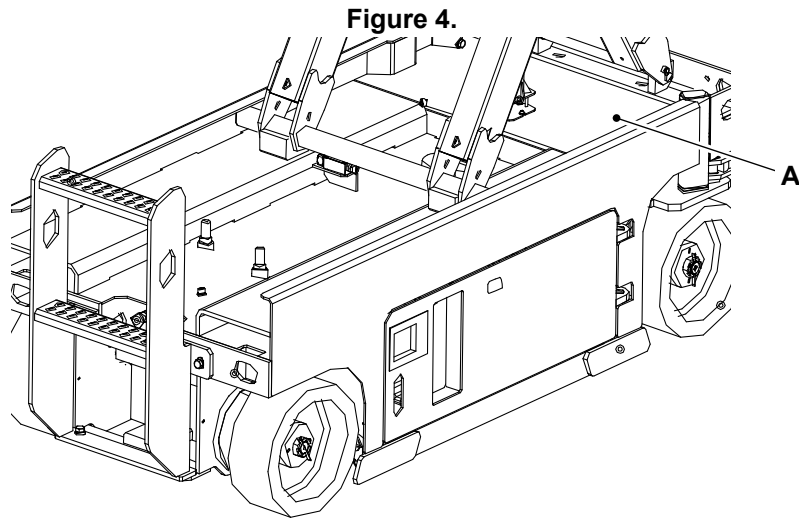

**A** Machine identification plate location

**Figure 5. Machine Identification Plate**

		JCB Access Limited LAKESIDE WORKS, ROCESTER, UTTOXETER, UNITED KINGDOM ST14 5JP		
Product Identification Number (PIN) ISO 10261				
Model		Max Wind Speed		m/s
Model Year		Max Inclination (Side)		°
Year of Manufacture		Max Inclination(Front/Rear)		°
Rated Load		kg	Electrical Supply	V/A
Rated Persons / tools		#/kg		
Unladen Weight		kg		
Max Manual Force		N		
MEWP Complying to EN280				400/E8950

## Safety Labels

### General

**▲ WARNING** Safety labels on the machine warn you of particular hazards. You can be injured if you do not obey the safety instructions shown.

The safety labels are strategically placed around the machine to remind you of possible hazards.

If you need eye-glasses for reading, make sure you wear them when reading the safety labels. Do not over-stretch or put yourself in dangerous positions to read the safety labels. If you do not understand the hazard shown on the safety label, then refer to Safety Label Identification.

Keep all of the safety labels clean and readable. Replace a lost or damaged safety label. Make sure the replacement parts include the safety labels where necessary. Each safety label has a part number printed on it, use this number to order a new safety label from your JCB dealer.

### Safety Label Identification

For: S1530E, S1930E .....	Page 10
For: S2032E, S2632E, S4550E .....	Page 12
For: S2046E, S2646E, S3246E, S4046E .....	Page 13

(For: S1530E, S1930E)

Figure 6.

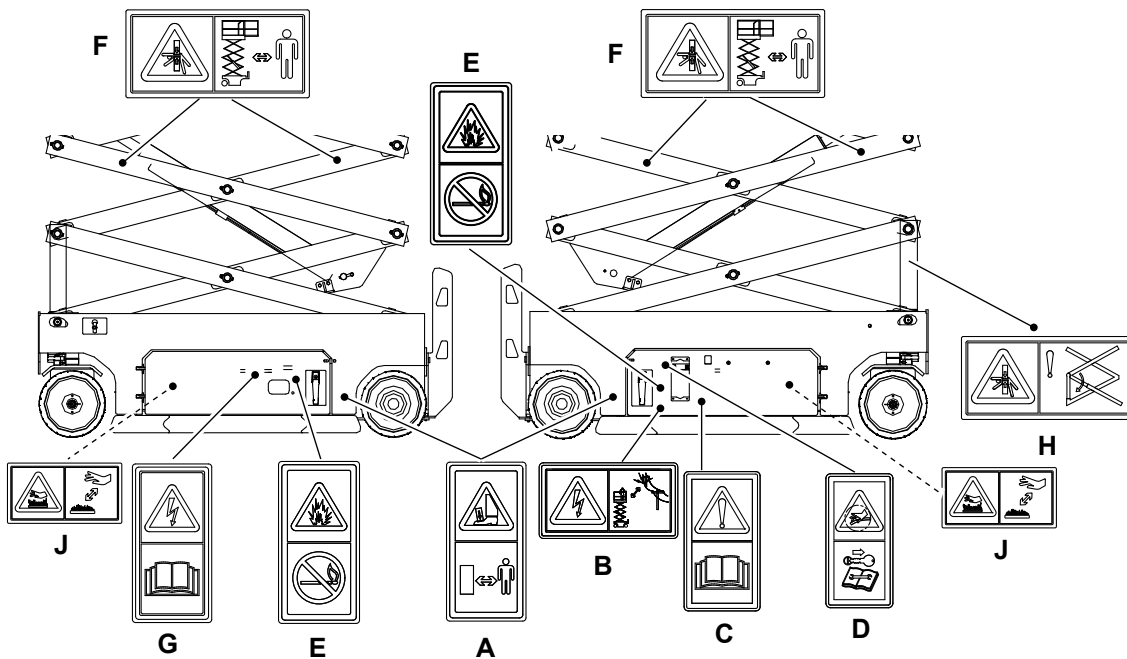

Figure 7.

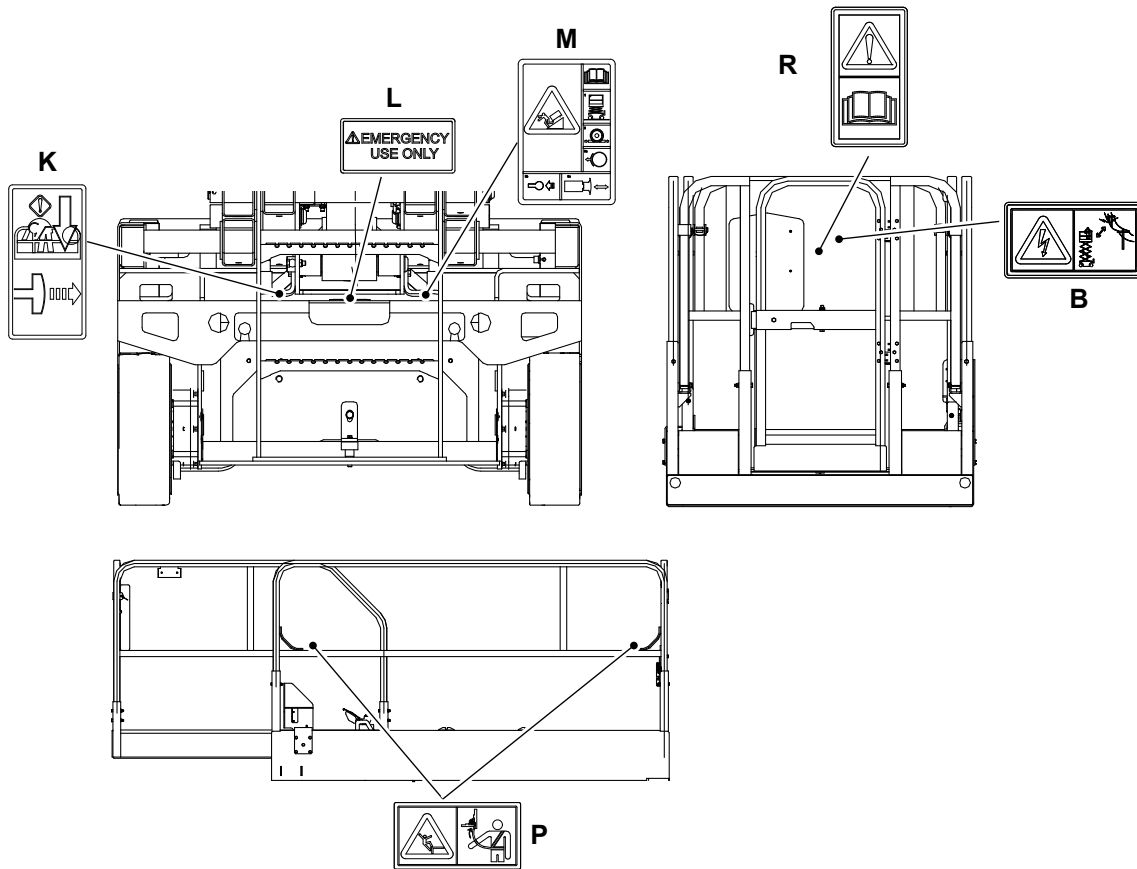

Table 1. Safety Labels

Item	Part No.	Description	Qty.
A	400/G0761	Crush hazard (to feet). Keep a safe distance. The attachment may roll forward when released.	4
B	400/D2107	Electrical hazard. Stay a safe distance away from power lines.	2
C	817/70092	Warning. Read the Operator's Manual before you operate the machine.	1
D	400/G0762	Pressure hazard. Stop the machine, remove the ignition key and consult service manual before carrying out any servicing and maintenance work.	1
E	400/G0767	Explosion hazard. Remove the sources of ignition.	2
F	400/D0831	Warning. Crush hazard. Keep a safe distance from scissor pack/mechanism.	4
G	400/G6092	Electrical hazard. Read operator's manual.	1
H	400/D2141	Warning. Engage safety strut before carrying out maintenance within the scissor pack.	1
J	332/P7128	Burns to fingers and hands. Stay a safe distance away.	2
K	400/G3529	Warning. Emergency descent control. Pull lever to lower the platform in the event that the operator is incapacitated.	1
L	400/D2576	Warning. Item for emergency use only.	2
M	400/D2979	Warning. Danger of uncontrolled machine movement. Platform to be in fully lowered position. Use wheel chocks. To release brakes, push valve and pump lever.	1
P	400/D1430	Wear safety harness.	4
R	400/G0705	Warning. Read operator's manual before operating machine.	1

(For: S2032E, S2632E, S4550E)

Figure 8.

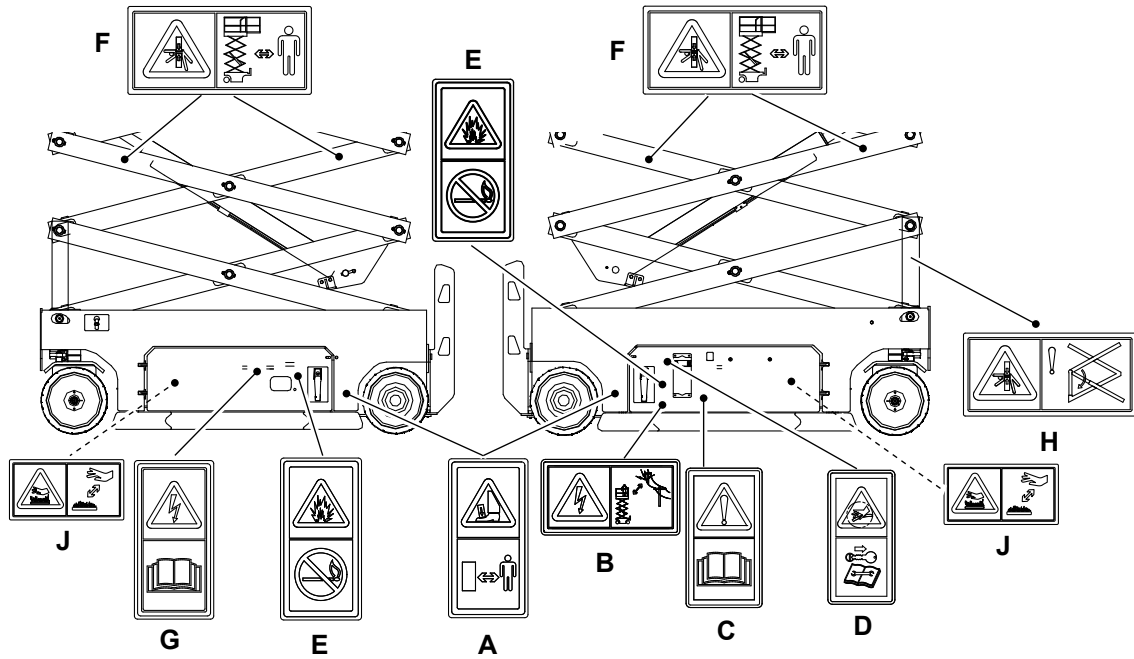

Figure 9.

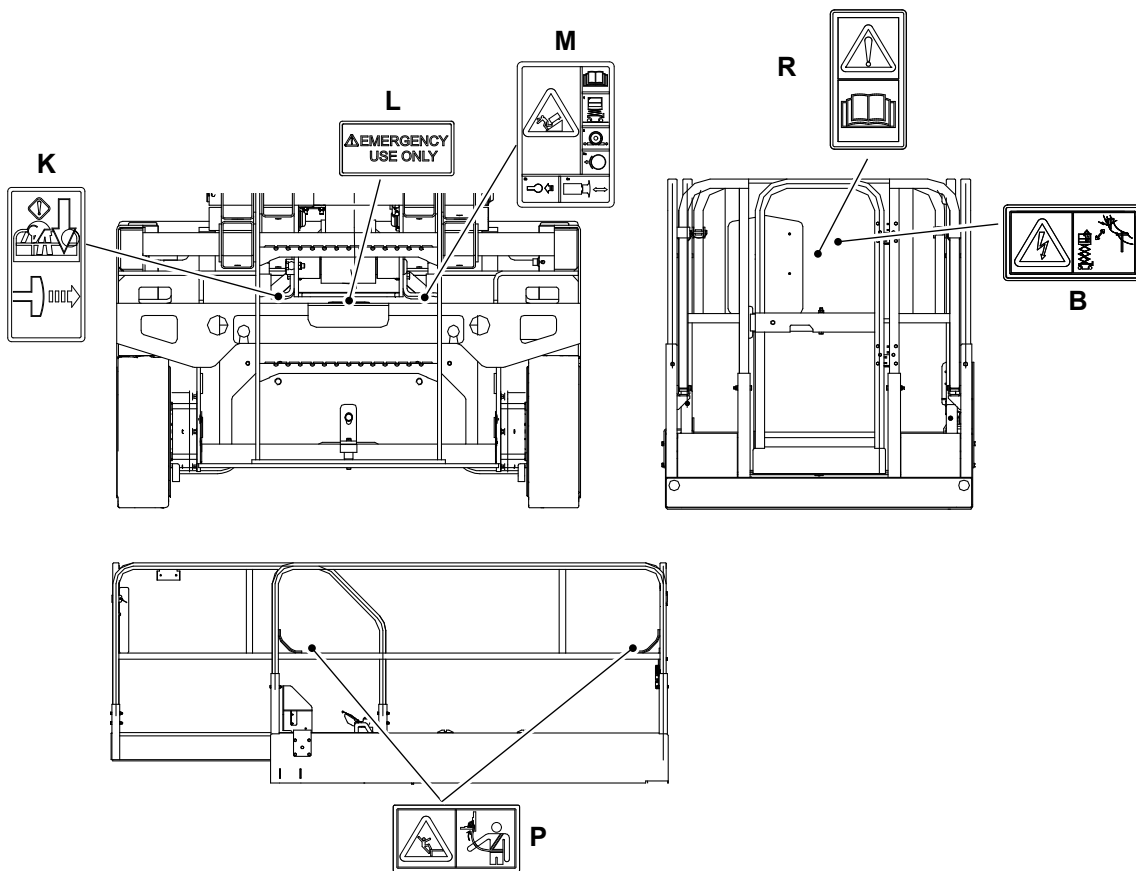

Table 2. Safety Labels

Item	Part No.	Description	Qty.
A	332/P7135	Crush hazard (to feet). Keep a safe distance. The attachment may roll forward when released.	4
B	400/D2107	Electrical hazard. Stay a safe distance away from power lines.	2
C	817/70092	Warning. Read the Operator's Manual before you operate the machine.	1
D	817/70002	Pressure hazard. Stop the engine, remove the starter key and consult the Service Manual before you complete any service or maintenance work.	1
E	817/70042	Explosion hazard. Remove sources of ignition.	2
F	400/D0831	Warning. Crush hazard. Keep a safe distance from scissor pack/mechanism.	4
G	817/70032	Electrical hazard. Read the Operator's Manual.	1
H	400/D2141	Warning. Engage safety strut before carrying out maintenance within the scissor pack.	1
J	332/P7128	Burns to fingers and hands. Stay a safe distance away.	2
K	400/G3529	Warning. Emergency descent control. Pull lever to lower the platform in the event that the operator is incapacitated.	1
L	400/D2576	Warning. Item for emergency use only.	2
M	400/D2979	Warning. Danger of uncontrolled machine movement. Platform to be in fully lowered position. Use wheel chocks. To release brakes, push valve and pump lever.	1
P	400/D1430	Wear safety harness.	4
R	400/G0705	Warning. Read operator's manual before operating machine.	1

(For: S2046E, S2646E, S3246E, S4046E)

Figure 10.

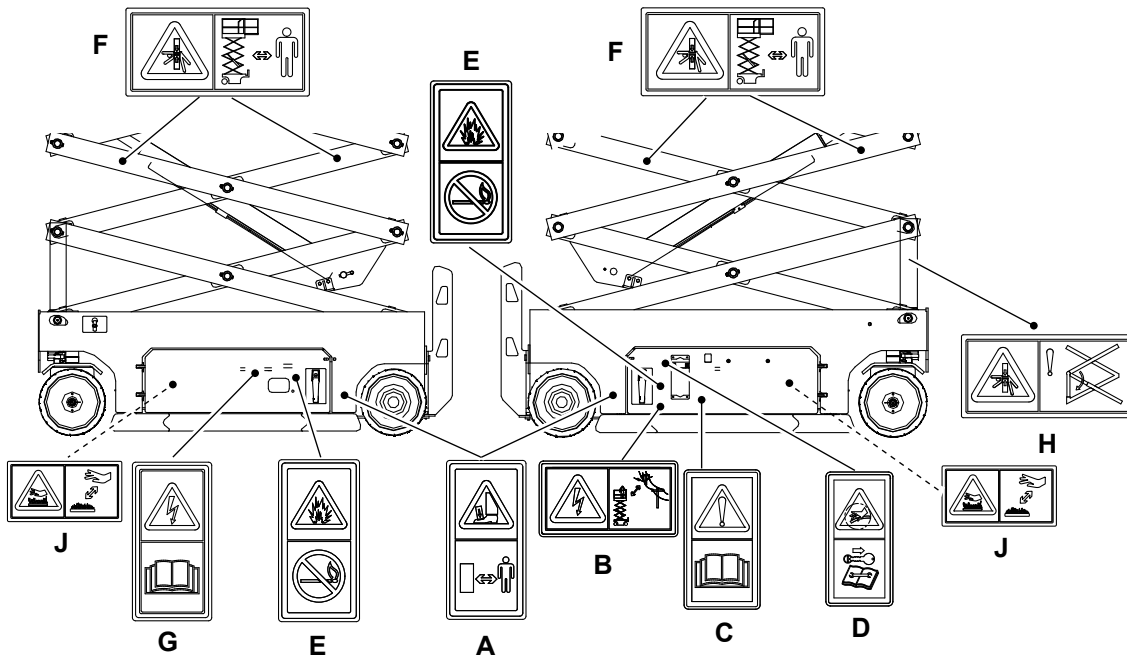

Figure 11.

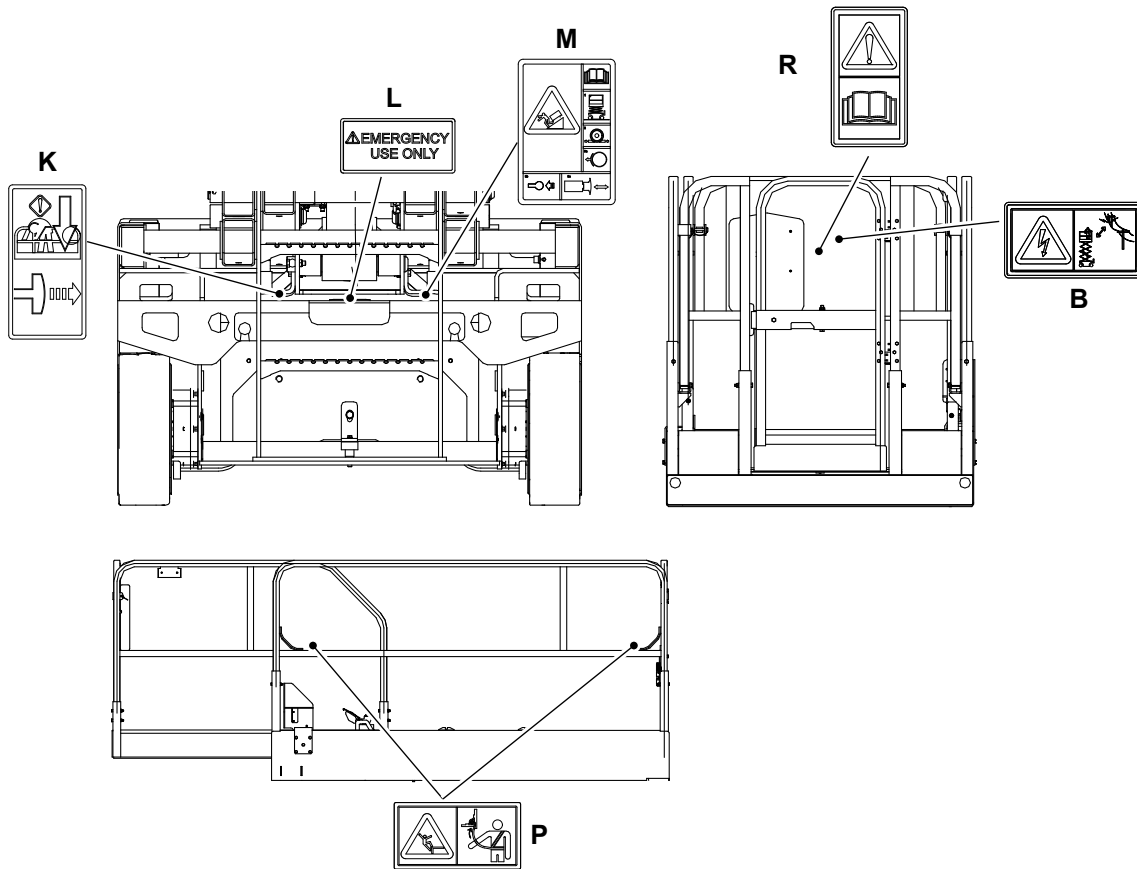

Table 3. Safety Labels

Item	Part No.	Description	Qty.
A	332/P7135	Crush hazard (to feet). Keep a safe distance. The attachment may roll forward when released.	4
B	400/D2107	Electrical hazard. Stay a safe distance away from power lines.	2
C	817/70092	Warning. Read the Operator's Manual before you operate the machine.	2
D	817/70002	Pressure hazard. Stop the engine, remove the starter key and consult the Service Manual before you complete any service or maintenance work.	1
E	817/70042	Explosion hazard. Remove sources of ignition.	2
F	400/D0831	Warning. Crush hazard. Keep a safe distance from scissor pack/mechanism.	4
G	817/70032	Electrical hazard. Read the Operator's Manual.	1
H	400/D2141	Warning. Engage safety strut before carrying out maintenance within the scissor pack.	1
J	332/P7128	Burns to fingers and hands. Stay a safe distance away.	2
K	400/G3529	Warning. Emergency descent control. Pull lever to lower the platform in the event that the operator is incapacitated.	1
L	400/D2576	Warning. Item for emergency use only.	2
M	400/D2979	Warning. Danger of uncontrolled machine movement. Platform to be in fully lowered position. Use wheel chocks. To release brakes, push valve and pump lever.	1
P	400/D1430	Wear safety harness.	4

# Operation Introduction

## General

The aim of this part of the manual is to guide the operator step-by-step through the task of learning how to operate the machine efficiently and safely. Read the Operation section through from beginning to end.

The operator must always be aware of events happening in or around the machine. Safety must always be the most important factor when you operate the machine.

When you understand the operating controls, gauges and switches, practice using them. Drive the machine in an open space, clear of people. Get to know the 'feel' of the machine and its driving controls.

Do not rush the job of learning, make sure you fully understand everything in the Operation section. Take your time and work efficiently and safely.

Remember:

- Be careful.
- Be alert.
- Be safe.

## Operating Safety

### General

#### Training

Make sure that you have had adequate training and that you are confident in your ability to operate the machine safely before you use it. Practice using the machine and its attachments until you are completely familiar with the controls and what they do. With a careful, well trained and experienced operator, your machine is a safe and efficient machine. With an inexperienced or careless operator, it can be dangerous. Do not put your life, or the lives of others, at risk by using the machine irresponsibly. Before you start to work, tell your colleagues what you will be doing and where you will be working. On a busy site, use a signalman.

Before doing any job not covered in this manual, find out the correct procedure. Your local JCB distributor will be glad to advise you.

#### Machine Condition

A defective machine can injure you or others. Do not operate a machine which is defective or has missing parts. Make sure the maintenance procedures in this manual are completed before using the machine.

#### Machine Limits

Operating the machine beyond its design limits can damage the machine, it can also be dangerous. Do not operate the machine outside its limits. Do not try to upgrade the machine performance with unapproved modifications or additional equipment.

#### Communications

Bad communications can cause accidents. Keep people around you informed of what you will be doing. If you will be working with other people, make sure any hand signals that may be used are understood by everybody. Worksites can be noisy, do not rely on spoken commands.

#### Parking

An incorrectly parked machine can move without an operator. Follow the instructions in the Operator's Manual to park the machine correctly.

#### Banks and Trenches

Banked material and trenches can collapse. Do not work or drive too close to banks and trenches where there is danger of collapse.

#### Safety Barriers

Unguarded machines in public places can be dangerous. In public places, or where your visibility is reduced, place barriers around the work area to keep people away.

#### Sparks

Explosions and fire can be caused by sparks from the electrical system. Do not use the machine in closed areas where there is flammable material, vapour or dust.

#### Regulations

Obey all laws, worksite and local regulations which affect you and your machine.

#### Electrical Power Cables

You could be electrocuted or badly burned if you get the machine or its attachments too close to electrical power cables.

You are strongly advised to make sure that the safety arrangements on site comply with the local laws and regulations concerning work near electric power lines.

Before you start using the machine, check with your electricity supplier if there are any buried power cables on the site.

There is a minimum clearance required for working beneath overhead power cables. You must obtain details from your local electricity supplier.

#### Machine Safety

Stop work at once if a fault develops. Abnormal sounds and smells can be signs of trouble. Examine and repair before resuming work.



### **Travelling at High Speeds**

Travelling at high speeds can cause accidents. Always travel at a safe speed to suit working conditions.

### **Confined Areas**

Pay extra attention to proximity hazards when operating in confined areas. Proximity hazards include buildings, traffic and bystanders.

### **Safe Working Loads**

Overloading the machine can damage it and make it unstable. Study the specifications in the Operator's Manual before using the machine.

### **Lightning**

If there is lightning, stay away from the machine and do not use the machine. If you are on the machine, exit the machine and get to safety. Do not attempt to mount or enter the machine.

If the machine is struck by lightning do not use the machine until it has been checked for damage and malfunction by trained personnel.

## **Worksite Safety**

"Workplace Inspection" will help operators to determine whether the workplace is suitable for operation. Operators must inspect the workplace before they move machines there. It is the operator's responsibility to understand and keep in mind the hazards in the workplace, He/she shall pay attention and avoid these problems when move, install and operate the machine. Check for hazards such as but not limited to:

- Drop-offs, or potholes including those concealed by water mud, etc.
- Slopes.
- Bumps and floor obstructions.
- Debris.
- Over head obstructions and electrical conductors.
- Hazardous locations and atmospheres.
- Inadequate surface and support to withstand all load forces imposed by the platform in all operating configurations.
- Wind and weather conditions.
- Presence of unauthorized persons.
- Other possible unsafe conditions.

## **Risk Assessment**

It is the responsibility of the competent people that plan the work and operate the machine to make a judgement about the safe use of the machine, they must take into account the specific application and conditions of use at the time.

It is essential that a risk assessment of the work to be done is completed and that the operator obeys any safety precautions that the assessment identifies.

If you are unsure of the suitability of the machine for a specific task, contact your JCB dealer who will be pleased to advise you.

The following considerations are intended as suggestions of some of the factors to be taken into account when a risk assessment is made. Other factors may need to be considered.

A good risk assessment depends on the training and experience of the operator. Do not put your life or the lives of others at risk.

### **Personnel**

- Are all persons who will take part in the operation sufficiently trained, experienced and competent? Are they fit and sufficiently rested? A sick or tired operator is a dangerous operator.
- Is supervision needed? Is the supervisor sufficiently trained and experienced?

- As well as the machine operator, are any assistants or lookouts needed?

### **The Machine**

- Is it in good working order?
- Have any reported defects been corrected?
- Have the daily checks been carried out?
- Are the tyres in good condition?
- Is the battery sufficiently charged to complete the job?

### **Working Area**

- Is it level?
- Is the ground solid? Will it support the weight of the machine when loaded?
- How rough is the ground? Are there any sharp projections which could cause damage, particularly to the tyres?
- Are there any obstacles or hazards in the area, for example, debris, excavations, manhole covers, power lines?
- Is the space sufficient for safe manoeuvring?
- Are any other machines or persons likely to be in or to enter the area while operations are in progress?

### **The Route to be Travelled**

- How solid is the ground, will it provide sufficient traction and braking? Soft ground will affect the stability of the machine and this must be taken into account.
- How steep are any slopes, up/down/across? A cross slope is particularly hazardous, is it possible to detour to avoid them?

### **Weather**

- How windy is it? High wind will adversely affect the stability of a loaded machine.
- Is it raining or is rain likely? The ground that was solid and smooth when dry will become uneven and slippery when wet, and it will not give the same conditions for traction, steering or braking.

### **Emergency Plan**

Make sure that emergency rescue plan is in place and understood by those involved when operating the machine from platform controller at height.

---

## Walk-Around Inspection

### General

The following checks must be made each time you return to the machine after leaving it for any period of time. We advise you also to stop the machine occasionally during long work sessions and do the checks again.

All these checks concern the serviceability of the machine. Some concern your safety. Get your service engineer to check and correct any defects.

1. Check for cleanliness.
  - 1.1. Remove dirt and debris, especially from around the linkages, rams, pivot points.
  - 1.2. Make sure the platform floor and handrails are clean and dry.
  - 1.3. Clean all of the safety and instructional labels. Replace any label that is missing or cannot be read.
2. Check for damage.
  - 2.1. Examine the machine generally for damaged and missing parts.
  - 2.2. Make sure that all of the fasteners and pivot pins are correctly installed.
  - 2.3. Check the operation of the platform side rails.
  - 2.4. Check the condition of the tyres.
  - 2.5. Check for leaks
3. Make sure that all of the access panels are closed correctly.
  - 3.1. If access panels are installed with locks, we recommend that you lock them to prevent theft or tampering.
4. Check the operation of all controls.
5. Check the operator's manual is in good condition and is kept in the operator's manual storage compartment.
6. Check the level of the hydraulic fluid and for leaks.
7. Check the visual condition of the batteries, cables and wiring.
8. Check the operation of the safety equipment.  
[Refer to: Check \(Operation\) \(Page 66\).](#)

## Entering and Leaving the Operator Station

### General

▲ **CAUTION** If the guardrails have been folded down, use extreme caution when entering and leaving the operator station. Do not operate the controls from the platform when the guard rails are folded.

**CAUTION** Entering or leaving the operator station must only be made where steps and handrails are provided. Always face the machine when entering and leaving. Make sure the step(s), handrails and your boot soles are clean and dry. Do not jump from the machine. Do not use the machine controls as handholds, use the handrails.

Make sure the machine is stopped, correctly parked and fully stowed before entering or leaving the platform. Refer to: [Stopping and Parking \(Page 24\)](#).

When entering and leaving the platform always maintain three points of contact with the guardrails and step. Do not use the machine controls as handholds.

### Entering the Platform

1. Hold the two guardrails, then use the steps to climb up to the platform. Refer to Figure 12.
2. Depress the lever and open the platform door.
3. Step into the platform.
4. Close the platform door and make sure it latches correctly.

### Leaving the Platform

1. Park the machine on solid (slabbed or paved), level ground.
2. Depress the lever and open the platform door.
3. Hold both of the guardrails and step backwards out of the platform onto the steps.
4. Close the platform door and make sure it latches correctly.
5. Use the steps to climb down backwards onto the ground.

Figure 12.

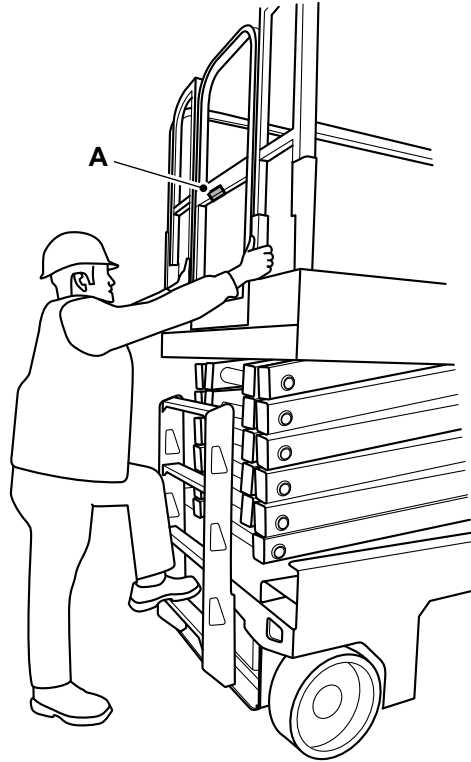

A Lever

## Battery Isolator

### General

▲ **WARNING** The batteries remain live even when the isolator key is removed.

### Disconnect the Machine Electrics:

1. Turn the key switch to the off position.
2. Get access to the battery isolator.  
[Refer to: Access Apertures \(Page 63\).](#)
3. Disconnect the battery isolator by pulling handle. Refer to Figure 13.

### Connect the Machine Electrics:

1. Make sure the key switch is at off position.
2. Connect the battery isolator.

Figure 13. Lead Acid Battery

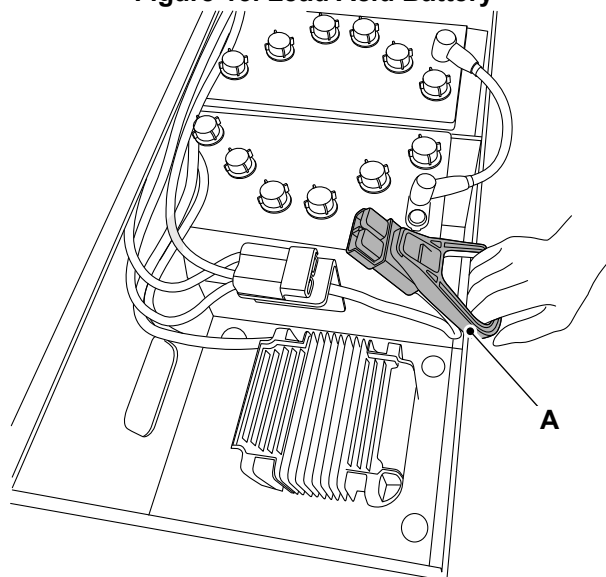

A Battery isolator

Figure 14. Lithium Iron Phosphate Battery

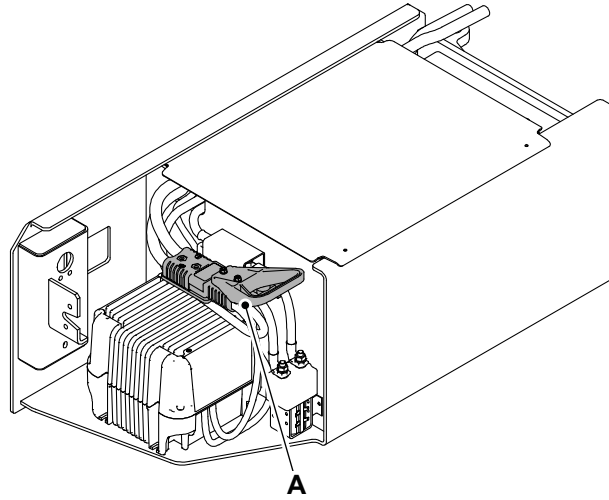

A Battery isolator

## Stopping and Parking

### General

This machine has brakes installed on the rear wheels only. The brakes installed on this machine are park brake only, there are no dynamic brakes installed.

The brake will release automatically during travel, the brake will not release during lifting.

1. Select a safe place to stop where the ground is firm and level such as slabbed or paved surface, where the machine will not cause an obstruction and away from heavy traffic.
2. Lower the platform.
3. Turn the key switch to the off position. Remove the key to avoid unauthorized use.
  - 3.1. Before switching off the machine check the battery level. If necessary, put the machine on charge to ensure that the battery is fully charged for the next time the machine is used.

### Brake Operational Limits

The machine brakes are capable of stopping the machine at its maximum speed on the maximum gradients as stated in this manual.

It is recommended that the machine is not parked or left unattended on slopes greater than those specified in this manual. It is the responsibility of the operator to assess the ground and atmospheric conditions before using or parking the machine on gradients.

The machine must be immediately taken out of service until corrected if the brakes do not operate within specifications or performance requirements as defined in this manual or any other in-service, periodic or post-maintenance brake verification.



## Getting the Machine Moving

### General

▲ **WARNING** Watch for obstructions around machine and overhead when driving. Check clearance above, to sides, at bottom of machine when lifting or lowering the platform.

**WARNING** Keep hands and arms out of the path of the scissor arms when lowering the platform.

**WARNING** Do not use the platform controller to release the platform when it is stuck, snagged or caught. In this case, use the ground controller only when there are no persons on the platform.

**CAUTION** Do not raise platform with the guardrails folded down. The guardrails must be in their upright positions and properly secured when raising the platform.

### Raising and Lowering the Platform

Refer to: [Operating Levers/Pedals \(Page 29\)](#).

#### Operation from the Ground

1. Turn the key switch to ground control.
2. Make sure the ground and platform emergency stop buttons are pulled out.
3. Move the platform raising/lowering toggle switch either up or down. Move up to raise the platform. Move down to lower the platform.
4. When lowering the platform the platform will stop part way down for safety. Release the toggle switch and check there are no obstructions in the scissors. Move the toggle switch down again to fully lower the platform. There is an intentional delay periods of 3 seconds after the stop and 1.5 seconds after the toggle switch is pressed during lowering.

#### Operation from the Platform

1. Turn the key switch to platform control.
2. Make sure the ground and platform emergency stop buttons are pulled out.
3. Press the raise/lower mode button on the platform controller. The button should illuminate.
4. Press and hold the enable switch.
5. Move the joystick forwards or backwards. Check the arrow colours on the joystick with the operating direction. Move forwards to lower the platform. Move backwards to raise the platform.

#### Operation in Raised Position

The automatic pothole protection system will fold down and drive speed is reduced when the platform raised.

## Slopes

### General

- ▲ **WARNING** Make sure that you have been trained and are familiar with the use of machines on slopes, and understand the adverse affects that slopes and site conditions can have on stability. Never use the machine on a slope if you do not understand the recommended practices for the use of machines in such applications.

There are a number of factors which can adversely affect the stability of the machine and the safety of the machine and operator when used on a slope.

It is essential that a risk assessment of the work to be done is completed and that the operator complies with any safety precautions that the assessment identifies.

### Driving on Slopes

- ▲ **WARNING** If the tilt indicator warning light/alarm is activated while driving with platform raised, lower the platform and drive to a smooth firm level surface.

While driving on slopes with the platform fully stowed make sure that the front/back and side slope does not exceed the rated gradient for the machine. [Refer to: Performance Dimensions \(Page 90\)](#).

Figure 15.

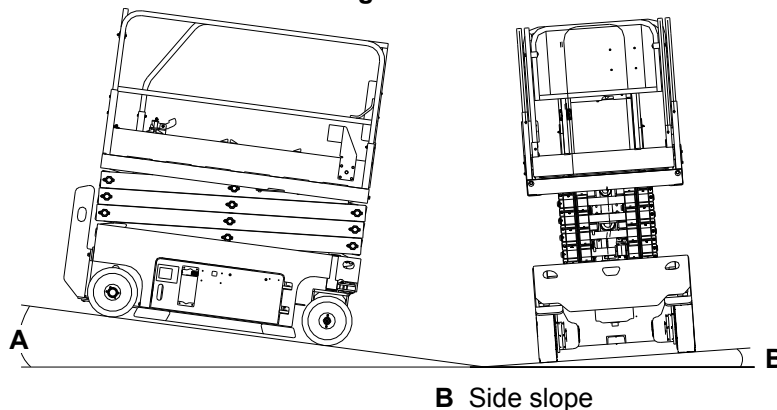

A Front/back slope

B Side slope

While driving on slopes with the platform raised make sure that front/back slope and side slope does not exceed the angles specified.

Front/back slope 3°

Side slope 1.5°

Figure 16.

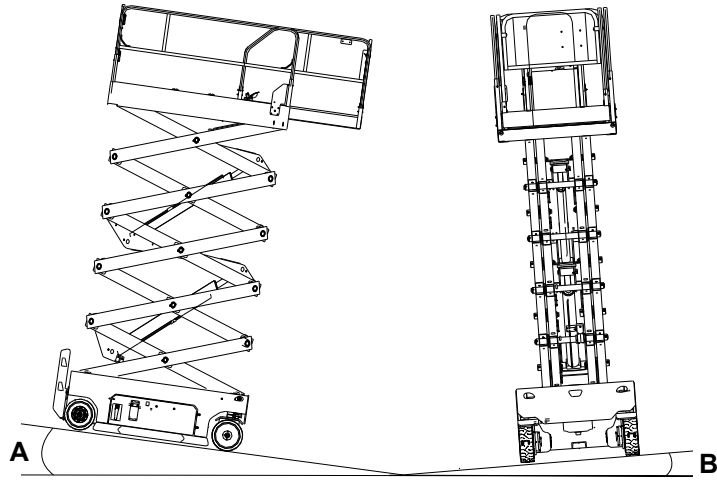

A Front/back slope

B Side slope

## Driving the Machine

### General

#### Operation from the Ground

1. Drive and steer functions are not available on the ground controller.

#### Operation from the Platform

Machine travel speed is restricted when the platform is raised.

1. Turn the key switch to platform control.  
[Refer to: Control Layouts \(Page 29\).](#)
2. Make sure the ground and platform emergency stop buttons are pulled out.
3. Press the drive mode button. The button should illuminate. Always check that the machine is in the correct mode before moving the joystick.
4. Press and hold the enable switch.
5. Slowly move the joystick forwards or backwards. Move forwards to move the machine forwards. Move backwards to move the machine backwards.

#### Drive Speed

There are two drive speeds available when the machine is stationary. Press the speed button to switch between high speed and low speed. When the light is illuminated slow speed is enabled. When the light is extinguished high speed is enabled. Slow speed is activated when the platform is raised. Always check that the machine is in the correct drive speed before moving the joystick, especially after lowering the platform.

#### Steering

Press and hold the enable switch. Press the steering switch left or right to change the steering direction of the steering wheels.

## Operating Levers/Pedals

### Control Layouts

- ▲ **CAUTION** Keep the machine controls clean and dry. Your hands and feet could slide off slippery controls. If that happens you could lose control of the machine.

### Ground Controller

- ▲ **WARNING** Do not operate the machine with the ground controller when there are personnel in the platform except in an emergency.

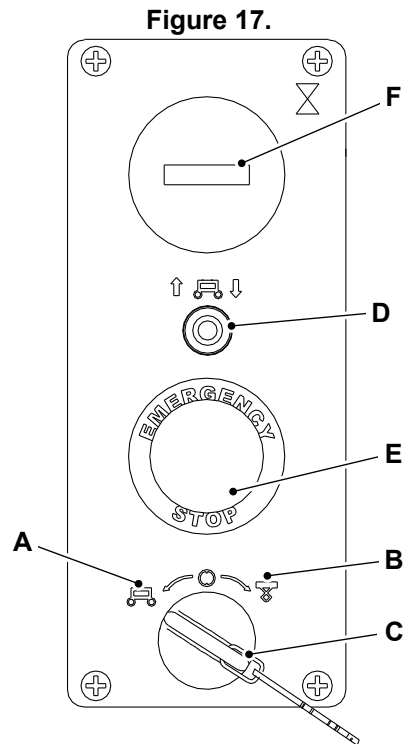

- |                                  |  |
|----------------------------------|--|
| <b>A</b> Ground control position | <b>B</b> Platform control position               |
| <b>C</b> Key switch              | <b>D</b> Platform raising/lowering toggle switch |
| <b>E</b> Emergency stop switch   | <b>F</b> Hourmeter                               |

### Platform Controller

- ▲ **WARNING** Do not drive the machine with the platform raised except on smooth, firm and level surface free of obstructions and pot holes.

Figure 18.

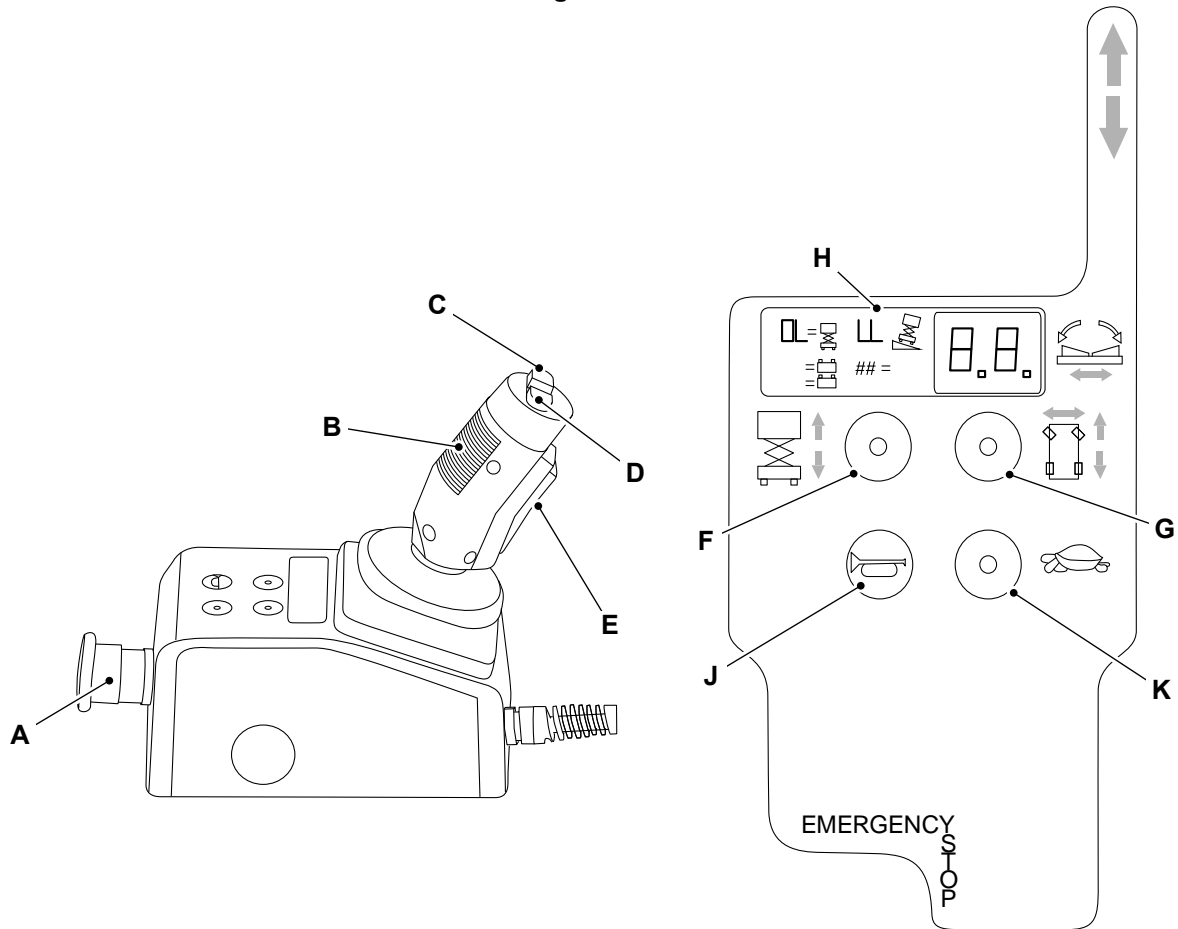

- A Emergency stop switch
- C Turn left switch
- E Safety trigger/enable switch
- J Horn button

- B Joystick (forwards/backwards)
- D Turn right switch
- F Raise/lower mode
- H Display
- K Speed button

The platform control lever is installed on a portable bracket that can be moved around the platform. The platform controller can be fitted to the ground controller to suit the operation.

Figure 19.

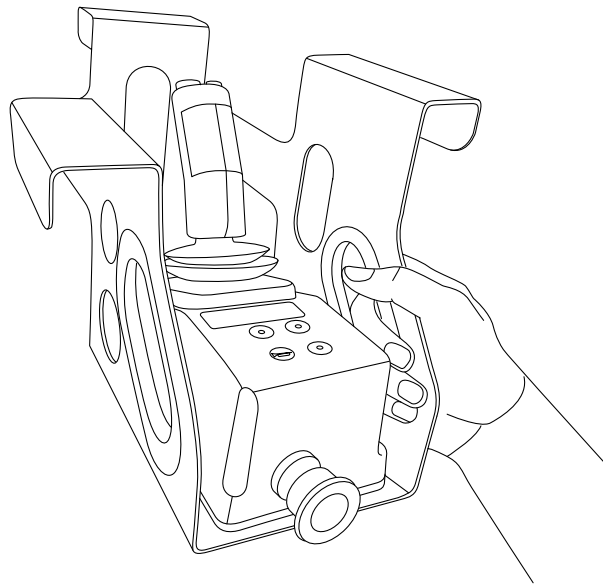

### Platform Controller Display

The display is used to show the battery level and error codes. [Refer to: Check \(Electrolyte Level\) \(Page 77\)](#). Refer to Figure 18.

[Refer to: Fault-Finding \(Page 101\)](#).

## Working with the Platform

### General

#### Trip and Fall Hazards

- Prior to operation, make sure that all operator door and guard rails are fastened and secured in their proper position.
- It is recommended that all persons in the platform wear full body harnesses with a short lanyard attached to an authorised lanyard anchor point while operating this machine. For further information refer to JCB dealer.
- Keep both feet firmly on the platform floor at all times. Never position ladders, boxes, steps, planks or other similar items on unit to provide additional reach for any purpose.
- Never use the scissor arm assembly to gain accesses to or leave the platform.
- Keep your footwear and the platform floor clean of oil, mud and slippery substances.

#### Electrocution Hazards

- This machine is not insulated and does not provide protection from contact or proximity to electrical current.
- Maintain distance from electrical lines, apparatus, or any energized (exposed or insulated) parts according to the Minimum Approach Distance. Refer to Table 4.
- Allow for machine movement and electrical line swaying.
- Maintain a clearance of at least 3m between any part of the machine and its occupants, their tools, and their equipment from any electrical line or apparatus carrying up to 50,000 volts. One foot additional clearance is required for every additional 30,000 volts or less.
- The minimum approach distance may be reduced if insulating barriers are installed to prevent contact, and the barriers are rated for the voltage of the line being guarded. These barriers shall not be part of (or attached to) the machine. The minimum approach distance shall be reduced to a distance within the designed working dimensions of the insulating barrier. This determination shall be made by a qualified person in accordance with the employer, local, or governmental requirements for work practices near energized equipment.

**Table 4. Minimum Approach Distance**

Voltage Range	Minimum Approach Distance
0 to 300 V	Caution!
300V to 50 KV	3m/10ft
50KV to 200KV	5m/15ft
200KV to 350KV	6m/20ft
350KV to 500KV	8m/25ft
500KV to 750KV	11m/35ft
750KV to 1000KV	14m/45ft

#### Tipping Hazards

- Make sure that the ground conditions are adequate to support the maximum tire load indicated on the tire load decals located on the chassis adjacent to each wheel. Do not travel on unsupported surfaces.
- The user must be familiar with the driving surface before driving. Do not exceed the allowable sideslope and grade while driving.
- Do not raise the platform or drive with platform raised while on or near a sloping, uneven, or soft surface. Make sure that the machine is positioned on the level, solid (slabbed or paved) ground before elevating platform or driving with the platform in the elevated position.
- Before driving on floors, bridges, trucks, and other surfaces, check allowable capacity of the surfaces.
- Never exceed the maximum work load as specified on the platform. Keep all loads within the confines of the platform. Evenly distribute the load across the platform, or the machine could become unstable.
- Do not operate the machine when wind conditions exceed the limit.
- Never attempt to use the machine as a crane. Do not tie-off machine to any adjacent structure. Never attach wire, cable, or any similar item to platform.
- If the platform or scissor pack becomes stuck or snagged on an adjacent or overhead structure, do not try to free the machine until all personnel are removed from the platform.
- Do not push or pull from the platform against any adjacent or overhead structures.
- Do not cover platform sides or carry large surface area items in the platform when operating outdoors. The addition of such items increases the exposed wind area of the machine.



- Do not increase platform size with unauthorised deck extensions or attachments.
- Do not raise the platform with the access apertures open. Keep the access apertures closed whilst the platform is raised.
- If the scissor arm or platform is caught so that one or more wheels are off the ground, all the persons and tools must be removed before attempting to free the machine. Use a crane, forklift truck, or other appropriate equipment to stabilise the machine and remove the personnel.

### Crushing and Collision Hazards

- Approved head protection must be worn by all operating and ground personnel.
- Keep hand and limbs out of the scissor arm assembly during operation and when raised unless safety strut installed.
- Watch for obstructions around machine and overhead when driving. Check clearance above, to sides, at bottom of machine when lifting or lowering the platform.
- Always post a lookout when driving in areas where vision is obstructed.
- Keep non-operating personnel at least 1.8m away from machine during all operations.
- Under all travel conditions, the operator must limit travel speed according to conditions of ground surface, congestion, visibility, slope, location of personnel, and other factors.
- Be aware of stopping distances in all drive speeds.
- Exercise extreme caution at all times to prevent obstacles from striking or interfering with operating controls and persons in the platform.
- Ensure that operators of other overhead and floor level machines are aware of the aerial work platform's presence. Disconnect power to overhead cranes. Barricade floor area if necessary.
- Do not operate over ground personnel. Warn personnel not to work, stand, or walk under a raised platform. Position barricades on floor as necessary.

### Platform Information Decals

The decals are located at the backboard of the platform.

**Figure 20.**

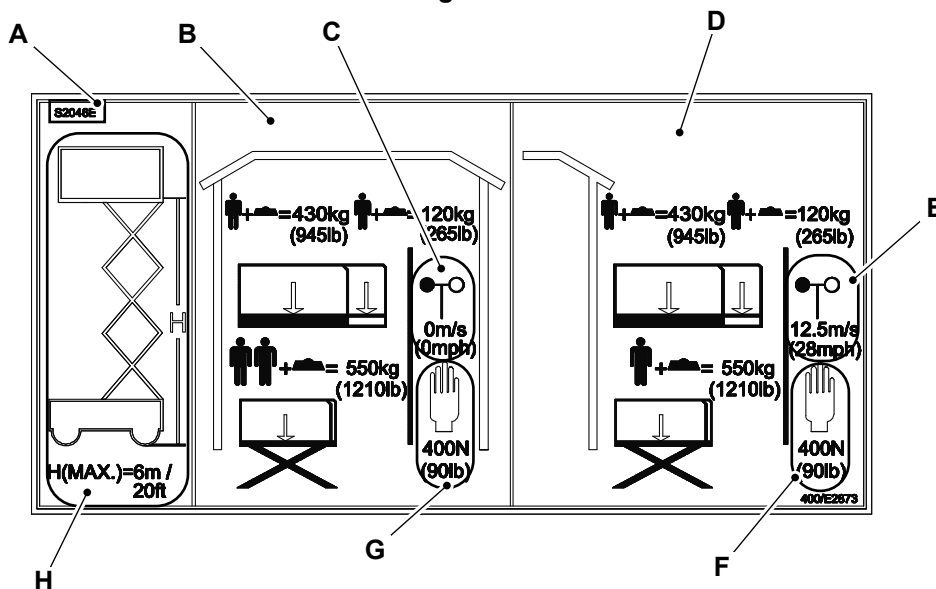

- A Machine model
- C Maximum wind speed
- E Maximum wind speed
- G Maximum manual force

- B Indoor rating
- D Outdoor rating
- F Maximum manual force
- H Maximum platform height

Figure 21.

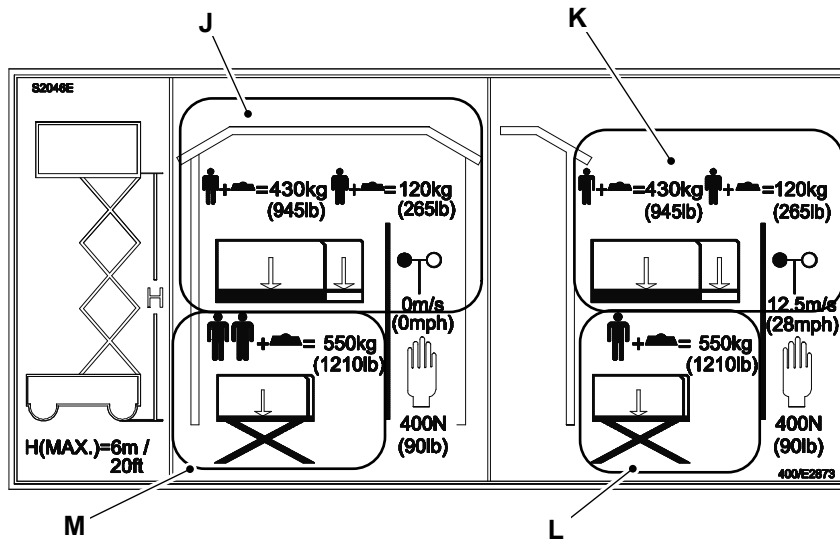

J Weight distribution on the extended platform  
L Weight distribution on the retracted platform

K Weight distribution on the extended platform  
M Weight distribution on the retracted platform

Figure 22.

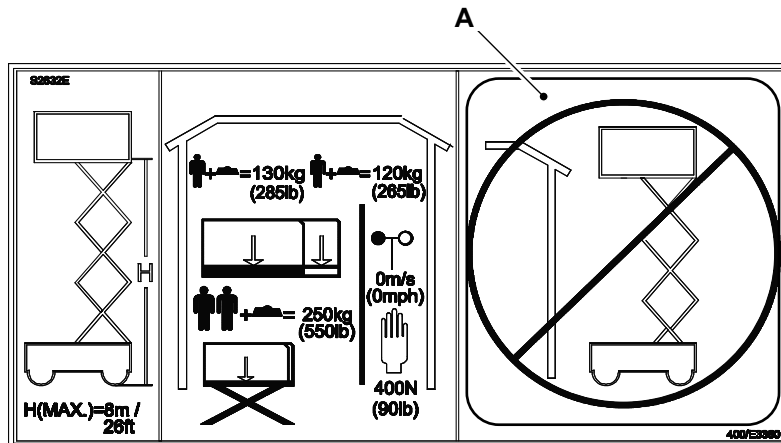

A Not suitable for outdoor use

The decals are located at the entry point of the platform.

Figure 23.

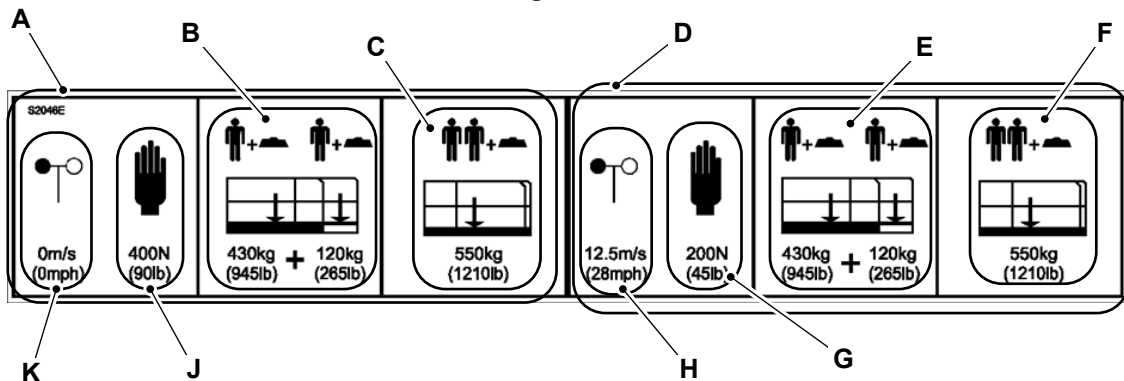

A Indoor rating (at 0m/s wind speed)  
C Weight distribution on the retracted platform  
E Weight distribution on the extended platform  
G Maximum manual force

B Weight distribution on the extended platform  
D Outdoor Rating (at 12.5m/s wind speed)  
F Weight distribution on the retracted platform  
H Wind speed

J Maximum manual force

K Wind speed

Figure 24.

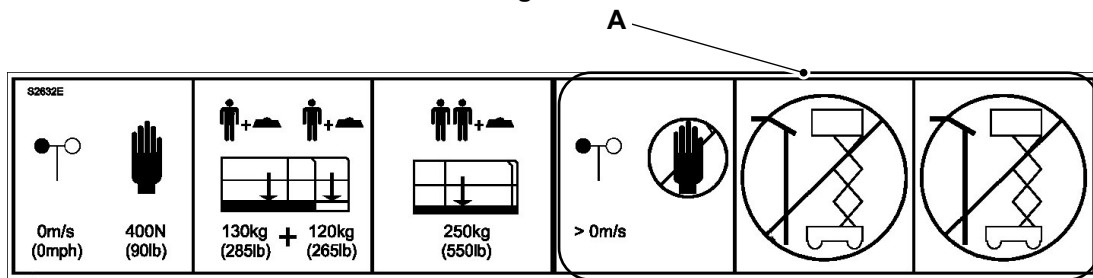

A Not suitable for outdoor use

## Extending and Retracting the Platform

**▲ WARNING** Do not exceed the maximum rated load stated on the platform.

**WARNING** Do not stand on the extension platform while it is moving or not fixed.

**CAUTION** Do not lower the platform without completely retracting the platform extension.

Make sure that platform door is latched correctly before extending or retracting the platform.

There are three fixing positions for the extending platform

1. Press the pedal.
2. Hold and push the extension platform guard rail.
3. Release the pedal when the rail is in one of the three fixing positions. Make sure that it is engaged correctly.

Figure 25.

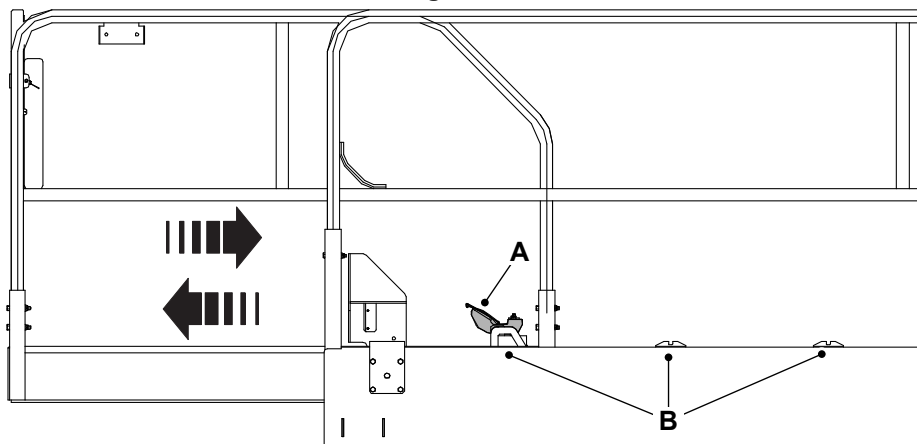

A Pedal

B Fixing positions

4. Press the pedal and pull the extended guardrail to retract the platform.

## Folding and Unfolding the Guardrails

**▲ CAUTION** If the guardrails have been folded down, use extreme caution when entering and leaving the operator station. Do not operate the controls from the platform when the guard rails are folded.

Fold the guardrails in order as shown. Refer to Figure 26.

1. To fold down each of guardrail, remove the lock pin for that guardrail.

2. Take a firm hold on the top of the guardrail, carefully lower it until it is fully folded. Follow the sequence of folding order

For unfolding the guardrails, follow the reverse sequence of folding order. Make sure that each lock pin is installed when guardrails are unfolded.

Figure 26.

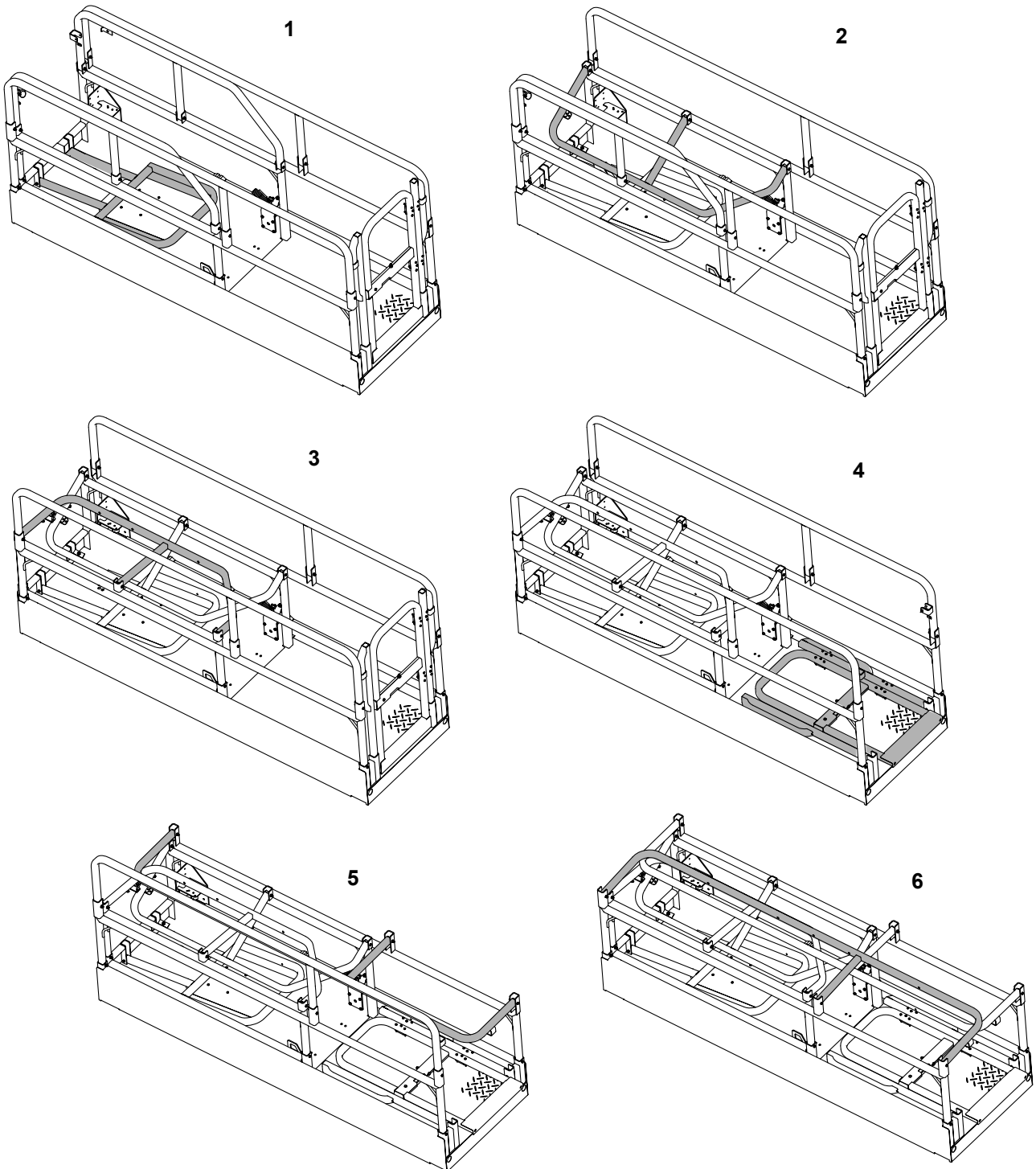

## Moving a Disabled Machine

### General

**▲ Notice:** Following any incident, thoroughly inspect the machine. Do not raise the platform until you are sure that all damage has been repaired and that all controls are operating correctly. Test all functions first from the ground controller, then from the platform controller.

**WARNING** Do not use the platform controller to release the platform when it is stuck, snagged or caught. In this case, use the ground controller only when there are no persons on the platform.

If the machine becomes disabled, the machine must be made safe, lifted onto a transporter and moved to a location where it can be repaired.

Towing, winching or pushing the machine without following the correct procedure will damage parts of the hydraulic system. If possible, repair the disabled machine where it stands.

### Lower the Platform (Emergency Operation)

The lowering alarm does not sound while lowering but if the machine is switched on the fault alarm will sound due to lowering without electrical controls. Lowering may continue.

To lower the platform in emergency conditions:

1. Pull out the emergency lowering lever. Refer to Figure 27.
2. Release the lever to stop the operation.

**Figure 27.**

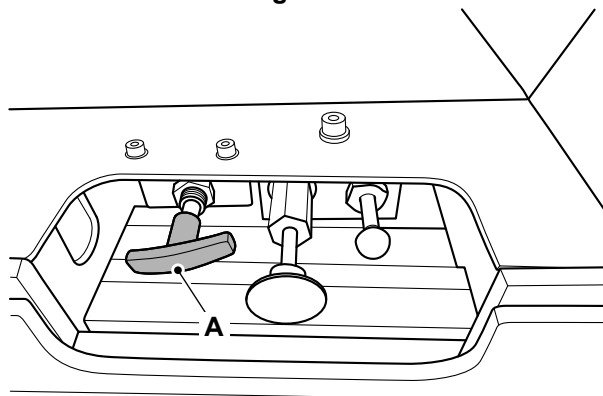

**A** Emergency lowering lever

### Brake Release Function

1. Put blocks at the front and rear of all four wheels. Make sure they are securely in place.
2. The release valve is at the back of the chassis.
3. Push in the black brake release handle to close the brake valve and trap the brake pressure. Refer to Figure 28.
4. Firmly pump the red brake release handle as required to release the brake. Refer to Figure 28.
5. Pull the black handle out after the machine is recovered to re-apply the brakes.

**Figure 28.**

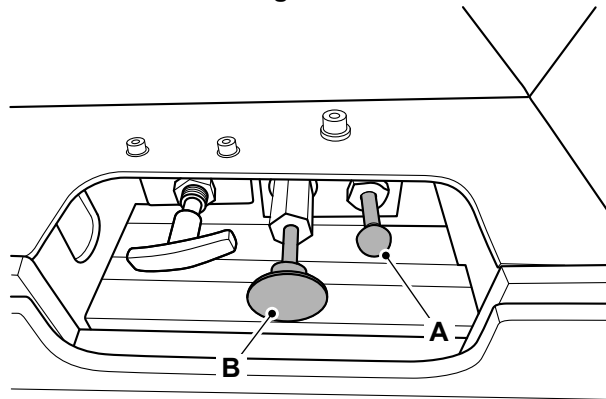

**A** Black brake release handle

**B** Red brake release handle

## Lifting the Machine

### General

#### Lifting by Forklift

Do not lift the machine from the side. Lifting the machine from the side may cause machine damage.

1. Make the machine safe with the platform lowered.
2. Check the extension platform, controller and chassis parts are correctly secured.
3. Remove any loose items from the machine.
4. Keep the machine in the lowered position while lifting with the forklift.
5. Use the forklift slots at the ladder side at the end of the machine.
  - 5.1. Align the forks with the forklift slots at the end of the machine.
  - 5.2. Drive the forklift forwards until the forks carriage almost touches the ladder
  - 5.3. When lifting the machine rotate the forks back slightly to ensure the machine will not slide off the forks. Travel with the machine at the specified distance from the ground.  
Length/Dimension/Distance: 0.4m
  - 5.4. Level the forks before landing the machine.

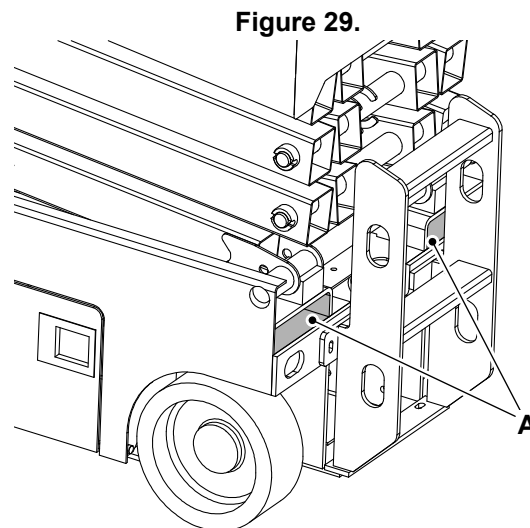

**A** Forklift slots

#### Lifting by Hoist

1. Make the machine safe with the platform lowered.
2. Check the extension platform, controller and chassis parts are correctly secured.
3. Remove any loose items from the machine.
4. Use the correct length of hoisting rope to prevent damage to the platform base and guardrail.
5. Make sure the hoist rigging is in the correct position. Adjust the hoist rigging to prevent machine damage and keep the machine in the level position.

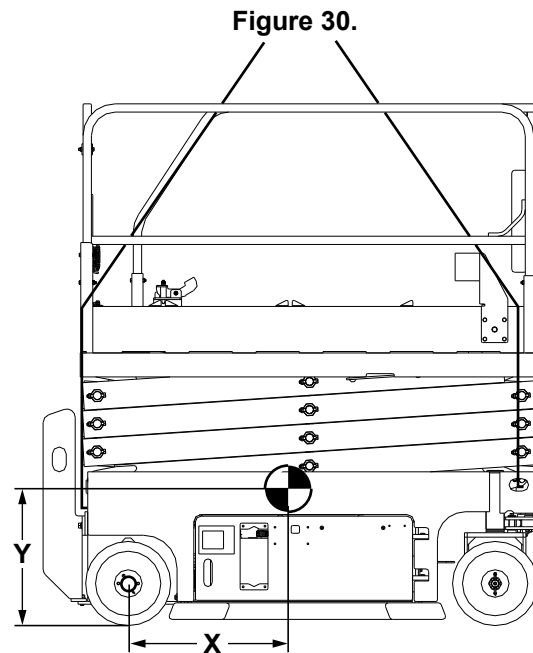

**X** X axis distance

**Y** Y axis distance

5.1. You must consider the location of the centre of gravity on the machine, when you lift the machine. Refer to Table 5.

**Table 5. Location of the Centre of Gravity**

Machine Model	X axis	Y axis
S1530E	620mm	511mm
S1930E	604mm	540mm
S2032E	955mm	625mm
S2632E	956mm	672mm
S2046E	801mm	530mm
S2646E	806mm	570mm
S3246E	808mm	638mm
S4046E	815mm	676mm
S4550E	1,058mm	754mm



---

## Transporting the Machine

### General

▲ **WARNING** The safe transit of the load is the responsibility of the transport contractor and driver. Any machine, attachments or parts that may move during transit must be adequately secured.

**CAUTION** Before moving the machine onto the trailer, make sure that the trailer and ramp are free from oil, grease and ice. Remove oil, grease and ice from the machine tyres. Make sure the machine will not foul on the ramp angle.

Check the condition of the transport vehicle before the machine is loaded on to its trailer.

Make sure that the transport trailer is suitable for the dimensions and weight of your machine. [Refer to: Static Dimensions \(Page 84\)](#).

Before transporting the machine make sure you will be obeying the local rules and laws regarding machine transportation of all the areas that the machine will be carried through.

### Loading the Machine onto the Transporting Vehicle/Trailer

Make sure that platform controller is correctly secured. Secure the platform controller to the guardrail at the mounting position provided in the front right corner of the platform. Insert a bolt through the controller cradle into the threaded hole provided.

### Lifting the Machine onto the Transporting Vehicle/Trailer

1. Turn the machine off and remove the key.
2. Remove any loose items from the machine.
3. Place the blocks at the front and rear of the trailer wheels.
4. Lift the machine on to the trailer.
5. Put blocks at the front and rear of all four wheels. Make sure they are securely in place.
6. Measure the maximum height of the machine from the ground. Make sure the truck driver knows the clearance height before he drives away.
7. If required remove the lock pins from all four corners of the platform and fold the guardrails.
8. Secure the machine to the trailer bed with suitable chains. Use the tie down points indicated by the safety decals.

Figure 31.

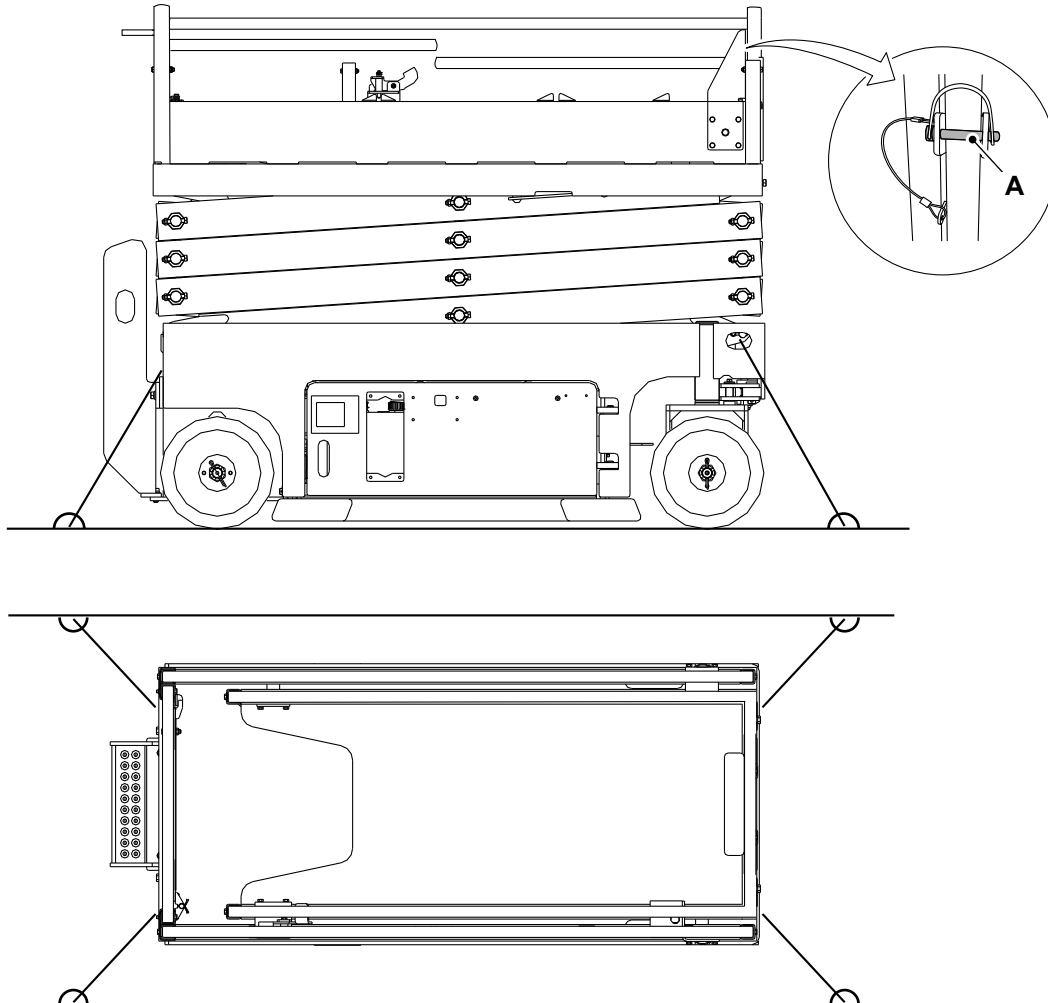

A Lock pin

### Driving the Machine onto the Transporting Vehicle/Trailer

1. Put the blocks at the front and rear of the trailer wheels.
2. Lower the ramps and check for suitability.  
[Refer to: Performance Dimensions \(Page 90\).](#)
3. Check the condition and security of the trailer side rails to make sure that the machine cannot be driven off the trailer.
4. Drive the machine onto the trailer and position it taking into account the load distribution.
5. Put blocks at the front and rear of all four wheels. Make sure they are secure in place.
6. Turn the machine off and remove the key.
7. Remove any loose items from the machine.
8. Measure the maximum height of the machine from the ground. Make sure the truck driver knows the clearance height before he drives away.
9. If required remove the lock pins from all four corners of the platform and fold the guardrails.
10. Secure the machine to the trailer bed with suitable chains. Use the tie down points indicated by the decals.



---

## Operating Environment

### General

For: Lead Acid Battery .....	Page 43
For: Lithium Iron Phosphate Battery .....	Page 43

#### (For: Lead Acid Battery)

In low and high temperature conditions, take the following precautions. They will make it easier to operate and prevent possible damage to your machine.

The machine has been designed to operate in atmospheric temperatures between -20°C (-4.0°F) and 46°C (114.7°F). The machine may be used down to -40°C (-39.9°F) with specialist equipment which is available from your JCB dealer.

#### (For: Lithium Iron Phosphate Battery)

In low and high temperature conditions, take the following precautions. They will make it easier to operate and prevent possible damage to your machine.

The machine has been designed to operate in atmospheric temperatures between -20°C (-4.0°F) and 46°C (114.7°F).

Full rate charging occurs in atmospheric temperatures between 0°C (32.0°F) and 46°C (114.7°F). Slow rate charging occurs in atmospheric temperatures below 0°C (32.0°F).



---

Notes:

---

---

---

---

---

---

---

---

---

---

---

---

---

# Preservation and Storage Storage

## General

For: Lead Acid Battery .....	Page 45
For: Lithium Iron Phosphate Battery .....	Page 45

### (For: Lead Acid Battery)

A long period of inactivity can be extremely harmful to lead acid batteries. When placing a battery into storage, follow the procedure below to ensure that the battery remains healthy and ready for use.

You can store, charge or operate the batteries on a concrete floor.

Avoid locations where freezing temperature are expected. Keeping a battery at a high state of charge will also prevent freezing. Freezing results in irreparable damage to the battery's plates and container.

Avoid direct exposure to heat sources, such as radiators or heaters. Temperatures above 26.6°C (79.8°F) accelerate the battery's self discharge characteristics.

## Storage Procedure

1. Completely charge the battery before storing.
2. Store the battery in cool, dry location, and protected from the elements.
3. During storage monitor the specific gravity (flooded) or voltage. Batteries in storage should give a boost charge when they show a 70% charge or less.
4. Completely charge the battery before re-activating.
5. For optimum performance, equalise the batteries (flooded) before putting them back into service.

### (For: Lithium Iron Phosphate Battery)

When storing the machine for prolonged periods, keep the batteries installed in the machine.

## Storage Procedure

1. Completely charge the battery before storing the machine.
2. Store the machine in a cool, dry location and protect from the elements.
3. If possible, store the machine with AC (Alternating Current) power connected.
4. If not stored connected to AC power, then connect AC power so that the batteries can charge for 48hrs before use.

## Take out of Storage

After long-term storage, it is recommended to service the machine before operation. For more information contact your JCB dealer.



---

Notes:

---

---

---

---

---

---

---

---

---

---

---

# Maintenance Introduction

## General

Your machine has been designed and built to give maximum performance, economy and ease of use under a wide variety of operating conditions. Prior to delivery, your machine was inspected both at the factory and by your dealer to make sure that it reaches you in optimum condition. To maintain this condition and trouble free operation it is important that the routine services, as specified in this manual, are done by an approved JCB dealer at the recommended specified intervals and it is recommended that this is done by an approved JCB dealer using genuine JCB parts. Servicing/repairs carried out by unauthorised personnel or the use of non-genuine inferior quality parts could limit machine warranty.

This section of the manual gives full details of the service requirements necessary to maintain your JCB machine at peak efficiency. A service manual for your machine is available from your JCB dealer. The service manual contains information on how to repair, disassemble and assemble your machine correctly.

It can be seen from the service schedules on the following pages that many essential service checks must only be done by a JCB trained specialist competent person. Only JCB dealer service engineers have been trained by JCB to do such specialist tasks, and only JCB dealer service engineers are equipped with the necessary special tools and test equipment to do such tasks, thoroughly, safely, accurately and efficiently.

After completing any routine maintenance or repairs you must complete the functional checks according to the maintenance schedule.

JCB regularly updates its dealers to advise them of any machine developments, changes in specifications and procedures. Therefore only a JCB dealer is fully able which makes them best placed to maintain and service your machine.

A service record sheet or book is provided which will enable you to plan your service requirements and keep a service history record. It must be dated, signed and stamped by your dealer each time your machine is serviced.

Remember, if your machine has been correctly maintained, not only will it give you improved reliability but its resale value will be greatly enhanced.

When the machine is removed from service, local regulations for machine decommissioning and disposal will vary. Contact your nearest JCB dealer for further information.

## Owner/Operator Support

JCB together with your dealer wants you to be completely satisfied with your new JCB machine. However, if you do have a problem, you can contact your dealers service department who are there to help you!

You will have been given the names of the relevant service contacts at your dealer when the machine was supplied.

To get the most from your dealer please help them to satisfy you by providing them with:

1. Your name, address and telephone number.
2. Your machine model and serial number.
3. The date of purchase and hours of work.
4. The nature of the problem.

Remember, only your JCB dealer has access to the vast resources available at JCB to help support you. In addition, your dealer is able to offer a variety of programmes covering warranty, fixed price servicing, safety inspections, including weight tests, covering both legal and insurance requirements.

## Service/Maintenance Agreements

To help plan and spread the costs of maintaining your machine, we strongly recommend you take advantage of the many service and maintenance agreements your dealer can offer. These can be tailor made to meet your operating conditions, work schedule etc.

Please consult your JCB dealer for details.

## Obtaining Spare Parts

If you use non-genuine JCB parts or consumables, then you can compromise the health and safety of the operator and cause machine failure.

A parts book for your machine is available from your JCB dealer. The parts book will help you identify parts and order them from your JCB dealer.

Your dealer will need to know the exact model, build and serial number of your machine. [Refer to: Product and Component Identification \(Page 9\)](#).

The data plate also shows the serial numbers of the engine, transmission and axle(s), where applicable. Remember, if any of these units have been changed, the serial number on the data plate may be wrong. Check on the unit itself.



---

## Maintenance Safety

### General

#### Raised Machine

Never position yourself or any part of your body inside the raised scissor pack which is not correctly supported. If the machine moves unexpectedly you could become trapped and suffer serious injury or be killed.

#### Compressed Air

Compressed air is dangerous. Wear personal protective equipment. Never point a compressed air jet at yourself or others.

#### Springs

Always wear personal protective equipment when dismantling assemblies containing components under pressure from springs. This will protect against eye injury from components accidentally flying out.

#### Metal Splinters

You can be injured by flying metal splinters when driving metal pins in or out. Use a soft faced hammer or copper drift to remove and install metal pins. Always wear personal protective equipment.

#### Repairs

If your machine does not function correctly in any way, get it repaired straight away. Neglect of necessary repairs could result in an accident or affect your health. Do not try to do repairs or any other type of maintenance work you do not understand. To avoid injury and/or damage get the work done by a specialist engineer.

#### Hydraulic Pressure

Hydraulic fluid at system pressure can injure you. Before connecting or removing any hydraulic hose, residual hydraulic pressure trapped in the service hose line must be vented. Make sure the hose service line has been vented before connecting or removing hoses. Make sure the machine cannot be started while the hoses are open.

#### 'O' rings, Seals and Gaskets

Badly installed, damaged or rotted 'O' rings, seals and gaskets can cause leakages and possible accidents. Renew whenever disturbed unless otherwise instructed. Do not use Trichloroethane or paint thinners near 'O' rings and seals.

#### Soft Ground

A machine can sink into soft ground. Never work under a machine on soft ground.

#### Working Under the Machine

Make the machine safe. Make sure the park brake is engaged and machine is fully isolated. Remove the machine key switch, disconnect the battery. Use blocks to prevent unintentional movement of the wheels.

#### Hydraulic Hoses

Never re-use hydraulic hose end crimps or use reusable hose end crimps.

#### Personal Protective Equipment

Use the appropriate personal protective equipment before performing maintenance on the machine, otherwise you could be injured.

#### Working at Height

Use appropriate access equipment such as ladders or a working platform if it is necessary to work at height to perform maintenance tasks on the machine. If you do not use suitable access equipment there is a risk of falling, resulting in personal injury or death.

### Fluids and Lubricants

#### Fluid Under Pressure

Fine jets of fluid at high pressure can penetrate the skin. Keep face and hands well clear of fluid under pressure and wear personal protective equipment. Hold a piece of cardboard close to suspected leaks and then examine the cardboard for signs of fluid. If fluid penetrates your skin, get medical help immediately.

## Hygiene

JCB lubricants are not a health risk when used correctly for their intended purposes.

However, excessive or prolonged skin contact can remove the natural fats from your skin, causing dryness and irritation.

Low viscosity oils are more likely to do this, so take special care when handling used oils, which might be diluted with fuel contamination.

Whenever you are handling oil products you must maintain good standards of care and personal and plant hygiene. For details of these precautions we advise you to read the relevant publications issued by your local health authority, plus the following.

## Storage

Always keep lubricants out of the reach of children.

Never store lubricants in open or unlabelled containers.

## Waste Disposal

**▲ CAUTION** It is illegal to pollute drains, sewers or the ground. Clean up all spilt fluids and/or lubricants.

Used fluids and/or lubricants, filters and contaminated materials must be disposed of in accordance with local regulations. Use authorised waste disposal sites.

**CAUTION** Damaged or spent batteries and any residue from fires or spillage must be put in a closed acid proof receptacle and must be disposed of in accordance with local environmental waste regulations.

All waste products must be disposed of in accordance with all the relevant regulations.

The collection and disposal of used hydraulic oil must be in accordance with any local regulations. Never pour used hydraulic oil into sewers, drains or on the ground.

## Handling

### New Oil

There are no special precautions needed for the handling or use of new oil, beside the normal care and hygiene practices.

### Used Oil

Here are precautions to protect your health when handling used hydraulic oil:

- Avoid prolonged, excessive or repeated skin contact with used oil
- Apply a barrier cream to the skin before handling used oil. Note the following when removing hydraulic oil from skin:
  - Wash your skin thoroughly with soap and water
  - Using a nail brush will help
  - Use special hand cleansers to help clean dirty hands
  - Never use petrol, diesel fuel, or paraffin for washing
- Avoid skin contact with oil soaked clothing
- Don't keep oily rags in pockets
- Wash dirty clothing before re-use
- Throw away oil-soaked shoes

## First Aid - Oil

### Eyes

In the case of eye contact, flush with water for 15min. If irritation persists, get medical attention.

### Swallowing

If oil is swallowed do not induce vomiting. Get medical advice.

### Skin

In the case of excessive skin contact, wash with soap and water.

### Spillage

Absorb with sand or a locally approved brand of absorbent granules. Scrape up and remove to a chemical disposal area.

### Fires

- ▲ **WARNING** Do not use water to put out an oil fire. This will only spread it because oil floats on water.  
Extinguish oil and lubricant fires with carbon dioxide, dry chemical or foam.

## Batteries

For: Lead Acid Battery .....	Page 51
For: Lithium Iron Phosphate Battery .....	Page 53

(For: Lead Acid Battery)

## Warning Symbols

- ▲ **DANGER** Set all switches to off before disconnecting and connecting the battery. When disconnecting the battery, take off the earth (-) lead first.

When reconnecting, attach the positive (+) lead first.

**DANGER** Batteries give off explosive gases. Keep flames and sparks away from the battery. Do not smoke close to the battery. Make sure there is good ventilation in closed areas where batteries are being used or charged. Do not check the battery charge by shorting the terminals with metal. Use a hydrometer or voltmeter.

**WARNING** Do not connect the charger when the batteries are not connected. Doing so could result in danger of live terminals from the charger.

Do not carry out maintenance on a machine whilst the charger is connected to an external power supply (i.e. do not work on a live machine). Cables from the charger to the batteries may remain live even if the batteries are disconnected/removed from the machine. There is a risk of serious electrical shock.

Always disconnect all external power supplies to the machine before carrying out maintenance.

**WARNING** Battery electrolyte is toxic and corrosive. Do not breathe the gases given off by the battery. Keep the electrolyte away from your clothes, skin, mouth and eyes. Wear safety glasses.

**CAUTION** Understand the electrical circuit before connecting or disconnecting an electrical component. A wrong connection can cause injury and/or damage.

**CAUTION** Damaged or spent batteries and any residue from fires or spillage must be put in a closed acid proof receptacle and must be disposed of in accordance with local environmental waste regulations.

The following warning symbols may be found on the battery.

Figure 32.

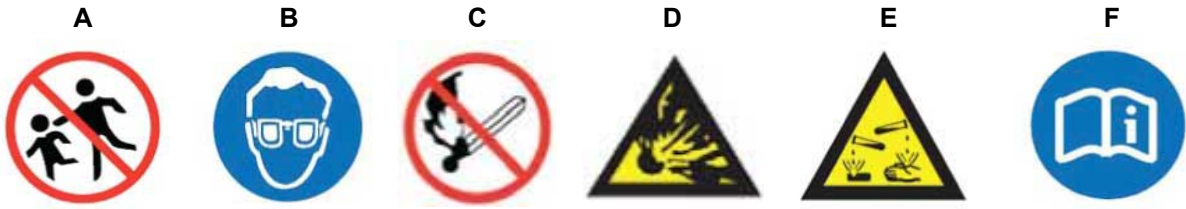

- A Keep away from children
- C No smoking, no naked flames, no sparks
- E Battery acid

- B Shield eyes
- D Explosive gas
- F Note operating instructions

## First Aid - Electrolyte

### Eyes

In the case of eye contact, flush with water for 15min. always get medical attention.

### Swallowing

Do not induce vomiting. Drink large quantities of water or milk. Then drink milk of magnesia, beaten egg or vegetable oil. Get medical help.

### Skin

Flush with water, remove affected clothing. Cover burns with a sterile dressing then get medical help.

(For: Lithium Iron Phosphate Battery)

## General Rules

**▲ DANGER** Set all switches to off before disconnecting and connecting the battery. When disconnecting the battery, take off the earth (-) lead first.

When reconnecting, attach the positive (+) lead first.

**WARNING** Do not connect the charger when the batteries are not connected. Doing so could result in danger of live terminals from the charger.

Do not carry out maintenance on a machine whilst the charger is connected to an external power supply (i.e. do not work on a live machine). Cables from the charger to the batteries may remain live even if the batteries are disconnected/removed from the machine. There is a risk of serious electrical shock.

Always disconnect all external power supplies to the machine before carrying out maintenance.

**CAUTION** Understand the electrical circuit before connecting or disconnecting an electrical component. A wrong connection can cause injury and/or damage.

Work on the Li-ion Battery should be carried out by qualified personnel only.

While working on the Li-ion Battery wear protective glasses and clothing.

Any uncovered battery material such as electrolyte or powder on the skin or in the eyes must be flushed with plenty of clean water immediately. Then seek medical assistance. Spillages on clothing should be rinsed out with water.

Terminals of the Li-ion Battery are always a live; therefore do not place items or tools on the Li-ion Battery. Avoid short circuits, too deep discharges and too high charge currents. Do not wear any metallic items such as watches, bracelets etc. In case of fire, you must use a type D, foam or CO2 fire extinguisher.

Never try to open or dismantle the Li-ion Battery. Electrolyte is very corrosive. In normal working conditions contact with the electrolyte is impossible. If the battery casing is damaged do not touch the exposed electrolyte or powder because it is corrosive.

Too deep discharges damage the Li-ion battery seriously and can even be dangerous. Therefore, JCB fit a safety relay within the system. Do not tamper or modify the existing system. If charged after the Li-ion battery was discharged below the Discharge cut-off voltage, or when the Li-ion battery is damaged or overcharged, the Li-ion battery can release a harmful mixture of gasses such as phosphate. Make sure there is good ventilation in closed areas where batteries are being used or charged.

It is recommended not to remove the LI-ion batteries from the machine. However if this is necessary, observe the following safety warnings: Li-ion Batteries are heavy. If involved in an accident they can become a projectile. Ensure adequate and secure mounting and always use suitable handling equipment for transportation. Handle with care because Li-ion Batteries are sensitive to mechanical shock.

## **Transportation**

The Li-ion battery must be transported in its original or equivalent package and in an upright position. If the battery is in its package, use soft slings to avoid damage. Do not stand below a Li-ion battery when it is hoisted. Never lift the battery at the terminals, only lift the battery at the handles.

Batteries are tested according to UN Handbook of Tests and Criteria, part III, sub section 38.3 (ST/SG/AC.10/11/Rev.5). For transport the batteries belong to the category UN3480, Class 9, Packaging Group II and have to be transported according to this regulation. This means that for land and sea transport (ADR, RID & IMDG) they have to be packed according to packaging instruction P903 and for air transport (IATA) according to packaging instruction P965. The original packaging satisfies these instructions.

## **Disposal**

Batteries marked with the recycling symbol must be processed via a recognized recycling agency. By agreement, they may be returned to the manufacturer. Batteries must not be mixed with domestic or industrial waste.

## **First Aid - Electrolyte**

### **Eyes**

In the case of eye contact, flush with water for 15min. always get medical attention.

### **Swallowing**

Do not induce vomiting. Drink large quantities of water or milk. Then drink milk of magnesia, beaten egg or vegetable oil. Get medical help.

### **Skin**

Flush with water, remove affected clothing. Cover burns with a sterile dressing then get medical help.

## Maintenance Schedules

### General

**▲ WARNING** Maintenance must be done only by suitably qualified and competent persons.

Before doing any maintenance make sure the machine is safe, it must be correctly parked on solid, level ground.

To prevent anyone starting the machine, remove the key. Disconnect the battery when you are not using electrical power. If you do not take these precautions you could be killed or injured.

A badly maintained machine is a danger to the operator and the people working around the operator. Make sure that the regular maintenance and lubrication tasks listed in the service schedules are done to keep the machine in a safe and efficient working condition.

Apart from the daily tasks, the schedules are based on time. Keep a regular check on the hourmeter readings to monitor the hourmeter equivalents. When there is no hourmeter installed, use the calendar equivalents to determine the service intervals.

Do not use a machine which is due for a service. Make sure any defects found during the regular maintenance checks are corrected immediately.

### How to Use the Maintenance Schedules

The schedules show the service tasks which must be done and their intervals.

The services must be done at either the hourly interval or the calendar equivalent, whichever occurs first.

The intervals given in the schedules must not be exceeded. If the machine is operated under severe conditions (high temperature, dust, water, etc.) shorten the intervals. Where local regulations require more frequent checks, the local regulations intervals should be followed.

**Table 6.**

<b>○</b>	Service task can be completed by a competent operator. Details of how to complete the service task are given in the Operator's Manual.
<b>□</b>	We recommend that a Service Engineer completes the service task. Details of how to complete the service task are given in the Service Manual.

### Maintenance Intervals

**Table 7.**

<b>Interval (h)</b>	<b>Calendar Equivalent</b>
10	Daily
50	Weekly
100	Monthly
250	Three months
500	Six months
1000	Yearly
1500	Eighteen months
2000	Two years

## Pre-start Cold Checks, Service Points and Fluid Levels

Table 8.

Component	Task	Daily	Weekly	Month-ly	3 Months	6 Months	Yearly	18 Months	2 Years
Operator's Manual	Check (condition)	○	○	□	□	□	□	□	□
Safety Labels	Check (condition)	○	○	□	□	□	□	□	□
Hydraulic hoses	Check (condition)	○	○	□	□	□	□	□	□
Hydraulic oil	Check (level)	○	○	□	□	□	□	□	□
Hydraulic oil	Check (leaks)	○	○	□	□	□	□	□	□
Hydraulic oil	Replace								□
Hydraulic return filter	Replace						□	□	□
Vent filter - hydraulic tank	Replace					□	□	□	□
Battery electrolyte (lead acid batteries)	Check (level)	○	○	□	□	□	□	□	□
Battery electrolyte (lead acid batteries)	Check (leaks)	○	○	□	□	□	□	□	□
Electric wire	Check (condition)	○	○	□	□	□	□	□	□
Welds	Check (condition)	○	○	□	□	□	□	□	□
Machine damage, missing parts	Check (condition)	○	○	□	□	□	□	□	□
Fasteners	Check (condition)	○	○	□	□	□	□	□	□
Lateral guard rail	Check (condition)	○	○	□	□	□	□	□	□
Chassis sliders	Check (condition)							□	□
Wheel rim and tyre	Check (condition)			□	□	□	□	□	□
Lift ram(s)	Grease				□	□	□	□	□
Steer pivots	Grease				□	□	□	□	□
Scissor base slider	Grease			□	□	□	□	□	□
Scissor basket slider	Grease				□	□	□	□	□
Wheel nut split pin	Check (condition)	○	○	□	□	□	□	□	□
Tilt sensor	Check (condition)	○	○	□	□	□	□	□	□
Pothole protection system	Check (condition)	○	○	□	□	□	□	□	□



## Functional Tests and Final Inspection

Table 9.

Component	Task	Daily	Weekly	Month-ly	3 Months	6 Months	Yearly	18 Months	2 Years
Ground controller									
Emergency stop	Check (operation)	○	○	□	□	□	□	□	□
Platform raise and lower functions	Check (operation)	○	○	□	□	□	□	□	□
Platform emergency lowering	Check (operation)	○	○	□	□	□	□	□	□
Ignition switch	Check (operation)	○	○	□	□	□	□	□	□
Platform controller									
Emergency stop	Check (operation)	○	○	□	□	□	□	□	□
Platform raise and lower functions	Check (operation)	○	○	□	□	□	□	□	□
Horn	Check (operation)	○	○	□	□	□	□	□	□
Steering	Check (operation)	○	○	□	□	□	□	□	□
Drive and brake	Check (operation)	○	○	□	□	□	□	□	□
General									
Limited driving speed (with platform lifted and stowed)	Check (operation)	○	○	□	□	□	□	□	□
Tilt sensor	Check (operation)	○	○	□	□	□	□	□	□
Pothole protection system	Check (operation)	○	○	□	□	□	□	□	□
Ventilation system- hydraulic tank	Check (operation)			□	□	□	□	□	□
Overload System	Check (operation)					□	□	□	□
Hydraulic system pressure	Check (settings)					□	□	□	□
Hydraulic system functional test	Check (operation)					□	□	□	□
Overload test	Check (operation)					□	□	□	□
RCBO (Residual current Circuit Breaker with Over current protection)	Check (operation)					□	□	□	□

## Maintenance Positions

### General

Make the machine safe before you start a maintenance procedure.

1. Park the machine on level, solid (slabbed/paved) ground.
2. Remove the machine key switch.
3. Disconnect the battery to prevent accidental operation.
4. Put the chocks on the side of all wheels.

### Maintenance Position- Platform Raised

**▲ WARNING** If a second person is involved with the operation ensure that the machine controls are not operated whilst they are in the working envelope of the machine and attachment, otherwise the other person could be killed or injured if a control is moved accidentally.

Make sure that the safety strut is installed before performing the maintenance task on raised platform.

When installing the upper safety strut always maintain three points of contact with ladder and scissor end bar. Use scissor end bar as handrails.

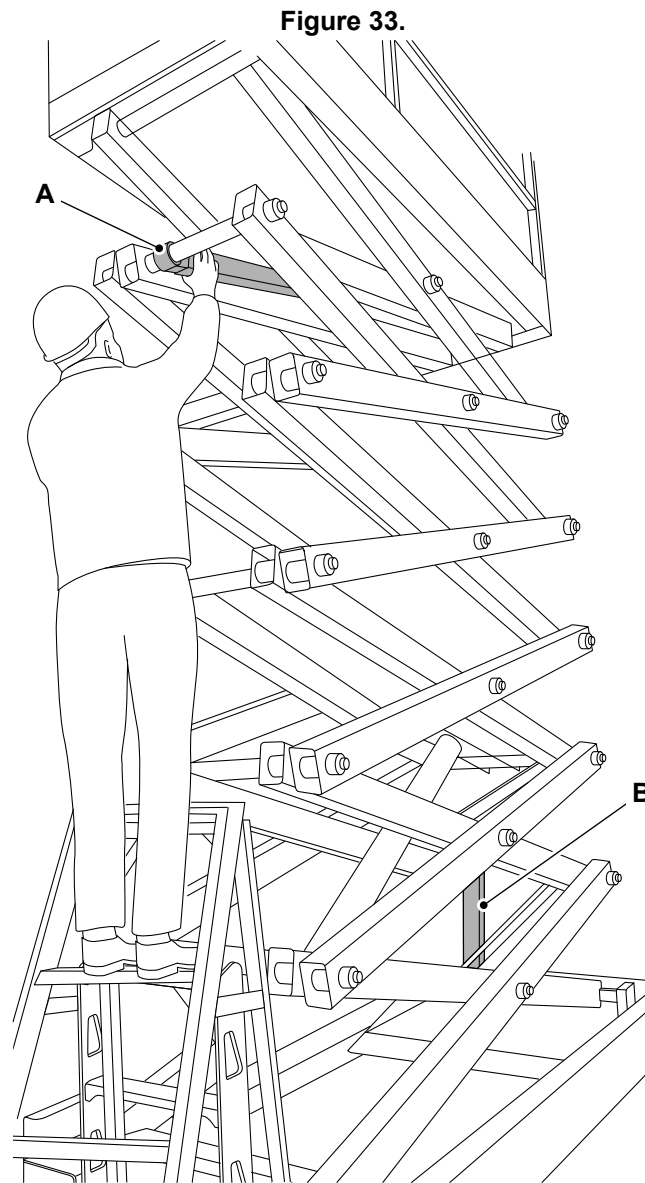

**A** Upper safety strut

**B** Lower safety strut

The minimum clearance height required to install the safety struts is shown. Refer to Table 10.

**Table 10.**

Machine	Length
S1530E	3.25m
S1930E	3.61m
S2032E	3.3m
S2046E	3.3m
S2632E	3.75m
S2646E	3.75m
S3246E	4.2m
S4046E	4.6m
S4550E	4.6m

### Maintenance Position- Platform Lowered

Make sure that the safety strut is in stored position before lowering the platform.

Figure 34.

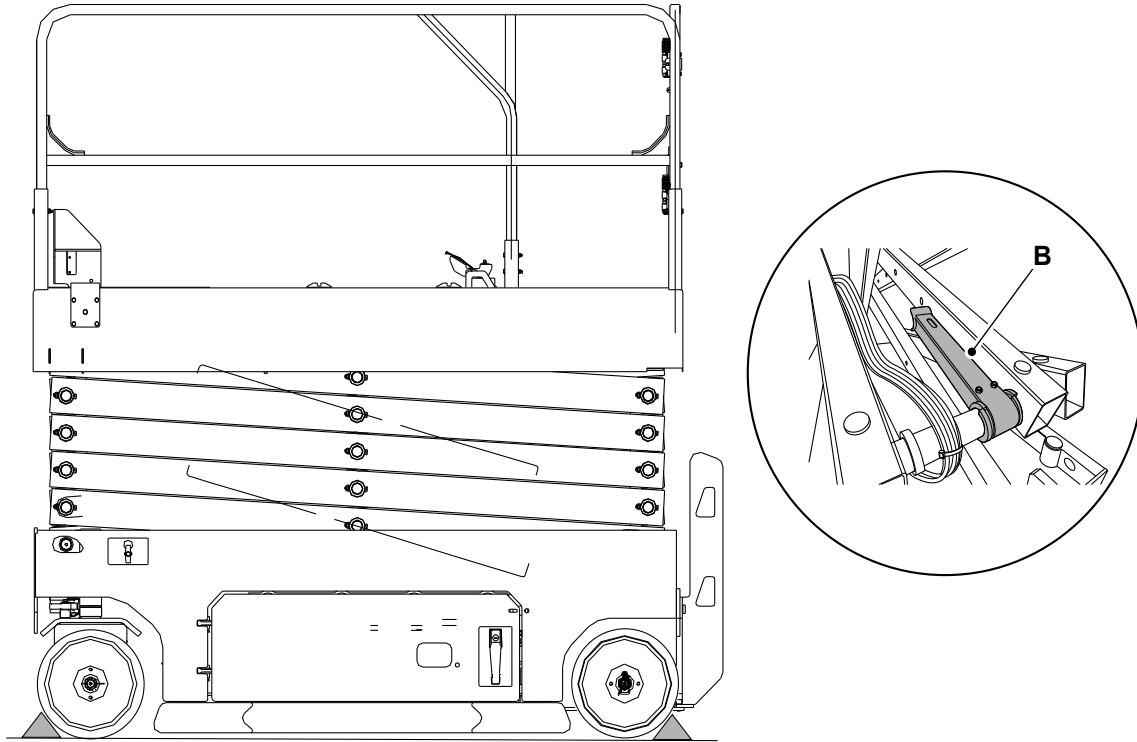

**B** Safety struts stowage position

## Service Points

### General

### Hydraulic Compartment

Figure 35.

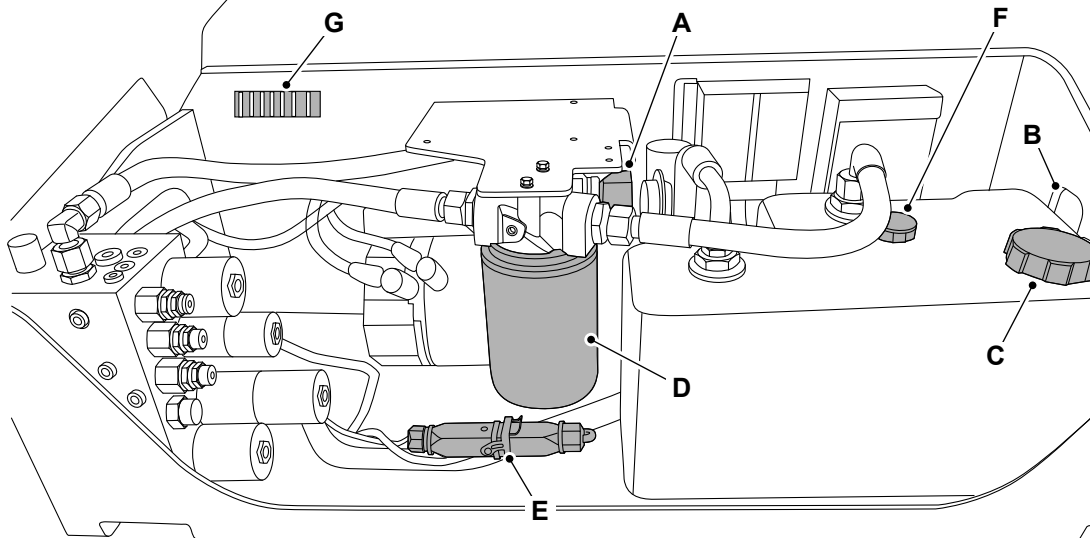

- A Main control relay
- C Hydraulic oil filler cap
- E Platform control connection
- G Secondary fuses

- B Hydraulic oil level indicator sight hole
- D Hydraulic oil filter
- F Hydraulic breather

## Battery Compartment

**Figure 36. Lead Acid Battery**

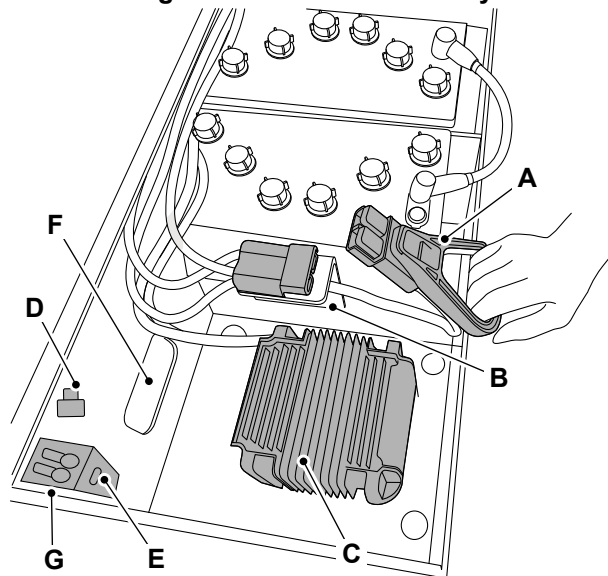

- A Battery isolator
- C Battery Charger
- E DC contactor resistor
- G DC contactor

- B Primary fuses (275A rating)
- D Primary fuse (20A rating)
- F Battery charger status sight hole

**Figure 37. Lithium Iron Phosphate Battery**

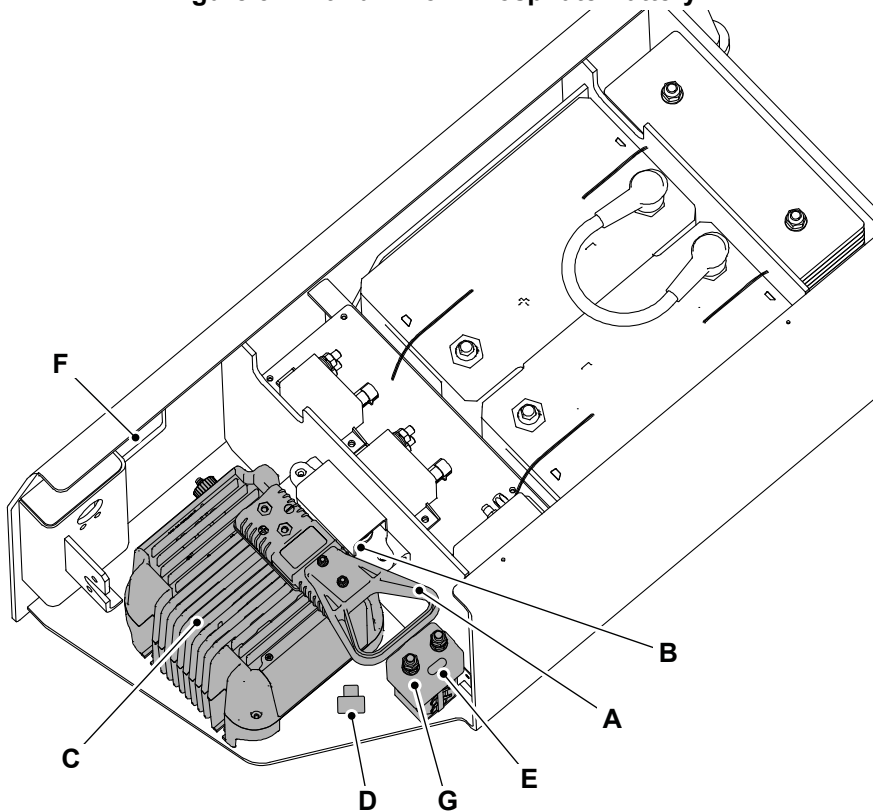

- A Battery isolator
- C Battery Charger
- E DC contactor resistor
- G DC contactor

- B Primary fuses (275A rating)
- D Primary fuse (20A rating)
- F Battery charger status sight hole

## Access Apertures

### General

**▲ WARNING** The hydraulic and battery components will be hot after the unit has been running. Allow the components to cool before servicing the unit otherwise you could be burned.

When moved to their maintenance position, the access panels give access to parts or areas of the machine that are not required during machine operation.

Before you operate the machine, make sure that all of the access panels are correctly in their closed or installed positions.

### Battery Cover

#### Open

1. Make the machine safe.
2. Remove the key from the machine.
3. Use the key to unlock the cover.
4. Press the lock and pull the handle to open the cover. Refer to Figure 38.

Figure 38.

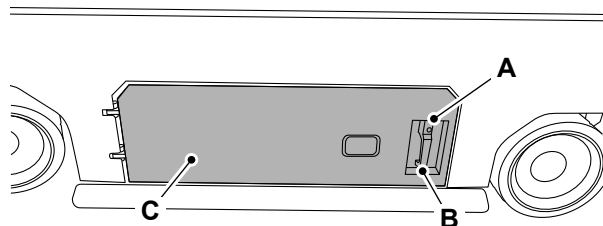

A Lock  
C Cover

B Handle

#### Close

1. Close the cover.
2. Make sure the cover is closed correctly.
3. Use the key to lock the cover. Refer to Figure 38.

### Hydraulic Compartment Cover

#### Open

1. Make the machine safe.
2. Remove the key from the machine.
3. Use the key to unlock the cover.
4. Press the lock and pull the handle to open the cover.

Figure 39.

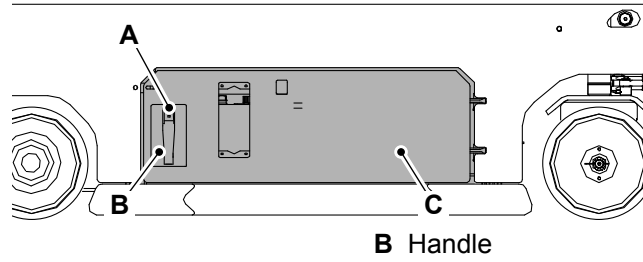

A Lock  
C Cover

B Handle

### Close

1. Close the cover.
2. Make sure the cover is secured correctly.
3. Use the key to lock the cover.



## **Body and Framework**

### **General**

#### **Check (Condition)**

1. Make sure that all of the guards and protective devices are in position, secured by their locking devices and free from damage.
2. Inspect all of the steelwork for damage. Include the following:
  - 2.1. Examine all of the pivot point welds.
  - 2.2. Examine the condition of all the pivot pins.
  - 2.3. Check that the pivot pins are correctly in position and secured by their locking devices.
3. Check the steps and guardrails are undamaged and correctly attached.
4. Check that all of the safety and instructional labels are undamaged and in position. Install new labels where necessary.
5. Note any damaged paintwork for future repair.
6. Inspect the machine for broken or loose fasteners.
7. Raise the platform until pot hole protection is activated. Check the condition of the pot hole protection bars.

## Safety Equipment

### Check (Operation)

If any of the safety equipment is defective stop using the machine until the defect has been rectified.

### Pot Hole Protection System

Pot hole protection system should be activated when the platform raised. The pot hole protection system is monitored by two limit switches to ensure correct deployment. If the pothole protection system does not activate the alarm will sound and the platform will not raise any higher.

1. Raise the platform.
2. Install the safety strut.
3. The pot hole protection plates should automatically unfold.
4. Inspect the pothole protection plates on both sides of the chassis. The plates should be lowered fully to the vertical position.
5. Inspect the linkages inside the compartments on both sides of the chassis. The linkages should be connected, with no visible signs of damage.
6. Remove the safety strut.
7. Lower the platform.
8. The pot hole protection plates should automatically fold.
9. Place an obstacle under the plate on each side.
10. Raise the platform. The platform should automatically stop when the plate cannot be deployed. Check the reaction: the alarm should sound at the platform controller and the chassis, the lights should flash on the chassis, the LCD (Liquid Crystal Display) displays should show "18".

Figure 40.

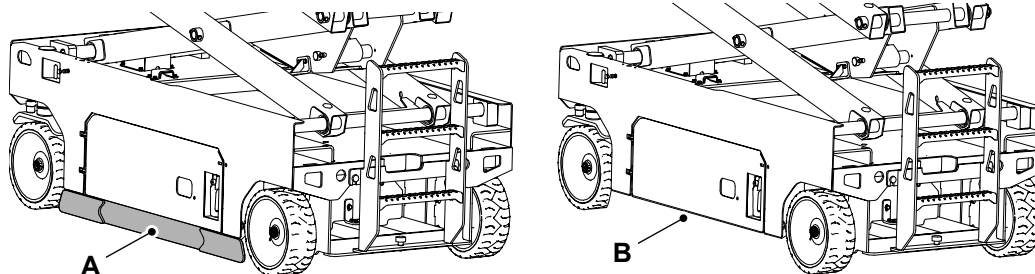

A Pot hole protection plate - unfold position

B Pot hole protection plate - fold position

### Tilt Sensor

1. Raise the platform.
2. Install the safety strut.
3. Use a pole/device to push the tilt sensor down on one side until the sensor is tilted at its highest angle. Hold the tilt sensor down at least for at least 1.5 seconds. Check the reaction: the alarm should sound at the platform controller and the chassis, the lights should flash on the chassis, the LCD displays should show "LL".

Figure 41.

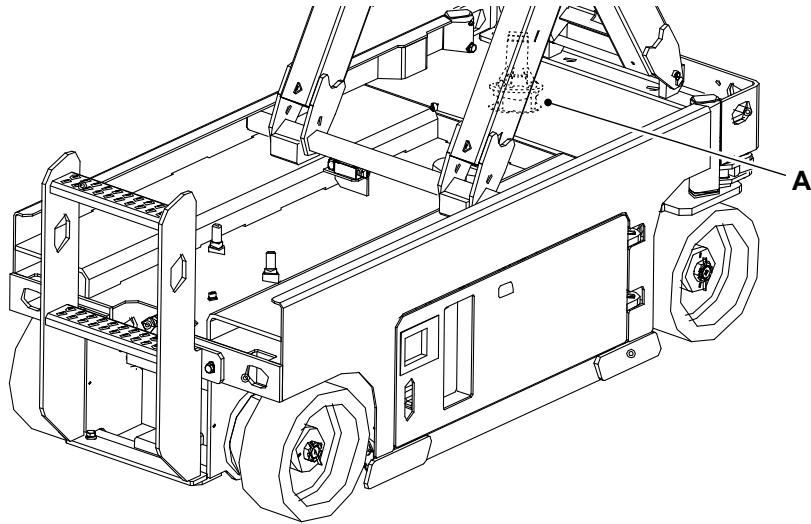

A Tilt sensor

---

## Brakes

### Park Brake

#### Check (Operation)

The brakes must be able to hold the machine on any slope it is able to climb. [Refer to: Driving on Slopes \(Page 26\)](#).

Make a note of the following.

- You must check the brakes for correct operation at regular intervals.
  - The correct brake function is necessary for safe machine operation.
  - The brake function must operate smoothly, free of hesitation, jerking and unusual noise.
  - Do this procedure with the machine on a firm, level surface that is free of obstructions.
1. Make the machine safe with the platform lowered.
  2. Make sure that the platform extension is in the fully retracted position.
  3. Put a mark on the ground to use as a test line.
  4. Turn the ignition switch to platform control.
  5. Pull out the ground emergency stop button to the ON position.
  6. Pull out the platform emergency stop button to the ON position.
  7. Make a note of the point on the machine (contact patch of a tyre) as a visual reference when you cross the test line.
  8. Press the drive function button (if installed).
  9. Press and hold the drive/steer function enable switch on the control handle.
  10. Move the control lever in the forward direction.
  11. Bring the machine to top drive speed before you reach the test line.
  12. Release the control lever when the selected reference point on the machine crosses the test line.
  13. Measure the distance between the test line and the machine reference point.
  14. Make sure that the braking distance is within the specified limits.
  15. Raise the platform.
  16. Do the steps 3 to 13 with the platform raised.
  17. Make sure that the braking distance is within the specified limits.

## Steering System

### General

#### Check (Operation)

1. Enable the joystick by pressing the safety trigger/enable switch.  
[Refer to: Operating Levers/Pedals \(Page 29\).](#)
2. Press the joystick (forward/back).
3. Press the left steering switch to turn left.
4. Press the right steering switch to turn right.

## Tyres

### General

#### Check (Condition)

Always drive with consideration for the condition of the tyres. Check the tyres daily for the signs of damage and wear. For example:

- Signs of distortion
- Cuts
- Embedded objects (nails, etc.)
- Continuous tread
- Edge damage
- Uneven wear

## Hydraulic System

### General

#### Check (Condition)

##### Hydraulic Hoses

**▲ WARNING** Damaged hoses can cause fatal accidents. Examine the hoses regularly. Do not use the machine if a hose or hose fixture is damaged.

**WARNING** Fine jets of fluid at high pressure can penetrate the skin. Keep face and hands well clear of pressurised fluid and wear protective glasses. If fluid penetrates your skin, get medical help immediately.

Examine the hoses for:

Damaged hose ends

Worn outer covers

Ballooned outer covers

Kinked or crushed hoses

Exposed armouring in the outer covers

Displaced hose end fittings.

Worn cover sheathing or hose burst protection covering.

Replace a damaged hose before you use the machine again.

The replacement hoses must be of the same size, standard and pressure rating. If necessary, for more information contact your JCB dealer.

#### Connecting the Hydraulic Hoses

1. Make the machine safe.  
[Refer to: Maintenance Positions \(Page 58\).](#)
2. Vent the hydraulic system.
3. Check the hoses and adaptors for damage.
4. Connect the hoses:
  - 4.1. Make sure that the hose is not twisted. Pressure applied to a twisted hose can cause the hose to fail or the connections to loosen.

Figure 42.

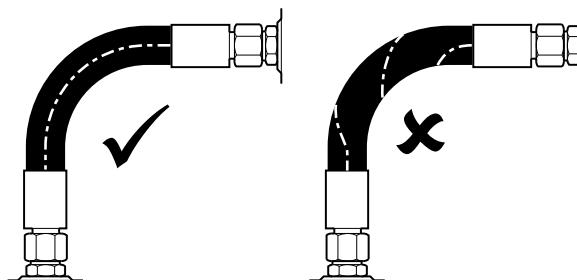

- 4.2. Make sure that the hose does not touch hot parts. High ambient temperatures can cause the hose to fail.
- 4.3. Make sure that the hose does not touch parts which can rub or cause abrasion.

- 4.4. Use the hose clamps (where possible) to support long hose runs and keep the hoses away from moving parts, etc.

Figure 43.

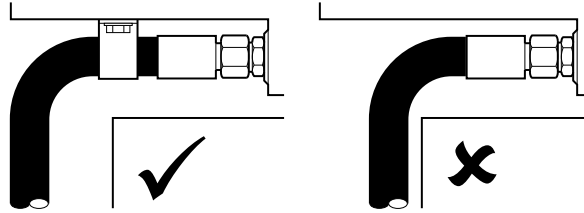

- 4.5. To allow for length changes when the hose is pressurised, do not clamp at the bend. The curve absorbs the change.

Figure 44.

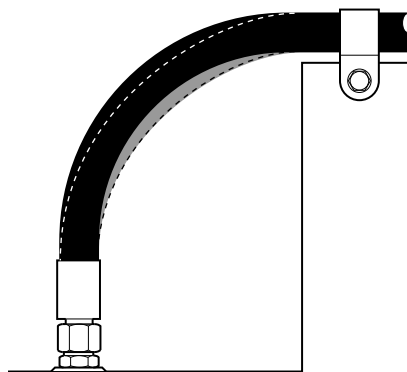

5. Check for leaks:

- 5.1. Start the machine.
- 5.2. Operate the related controls to increase the pressure in the hydraulic system.
- 5.3. Stop the machine then remove the key.
- 5.4. Check for indications of leakage at the hose connections. Correct, as necessary.

### Disconnecting the Hydraulic Hoses

1. Make the machine safe.  
[Refer to: Maintenance Positions \(Page 58\).](#)
2. Vent the hydraulic system.
3. Disconnect the hoses.
4. Check the hoses and adaptors for damage.
5. If necessary, install the blanking caps.
6. Check for leaks:
  - 6.1. Start the machine.
  - 6.2. Operate the related controls to increase the pressure in the hydraulic system.
  - 6.3. Stop the machine then remove the key.
  - 6.4. Check for indications of leakage at the hose connections. Correct, as necessary.



## Quick Release Couplings

**▲ WARNING** The external surfaces of the couplings must be clean before connecting or disconnecting. Ingress of dirt will cause fluid leaks and difficulty in connecting or disconnecting. You could be killed or seriously injured by faulty quick release couplings.

The flat face quick release couplings allow the operator to remove and install attachments swiftly and efficiently.

Generally, your machine pipework will be installed with a female coupling and a male coupling. The optional attachment hoses will also be installed with a female coupling and a male coupling.

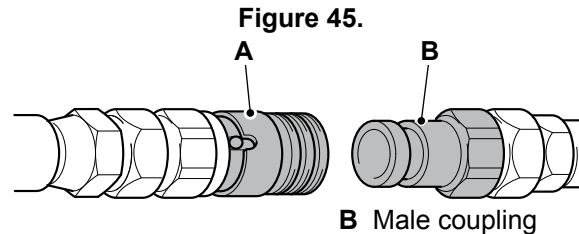

The quick release couplings will be trouble free and relatively easy to connect and disconnect, if they are kept clean and used correctly. The recommendations listed below must always apply when using flat face quick release couplings.

Read the correct connecting and releasing procedures before you install or remove any optional attachment connected with quick release couplings.

### Essential do's:

- Before connecting or removing any hydraulic hose, the residual hydraulic pressure trapped in the service hose line must be vented. Make sure the hose service line has been vented before connecting or removing the hoses.
- Always wipe the two mating faces clean before connecting.
- Use caps and plugs when the couplings are disconnected.
- Always align the external locking ball (if used) with the notch in the locking sleeve and then pull the locking sleeve back fully to disconnect.
- If a coupling sticks, first check that pressure has been released. Make sure the locking ball and notch in the locking sleeve are aligned, pull back the sleeve and twist the couplings apart. Sticking is normally caused by dirt in the coupling or physical damage due to abuse.
- Connect and disconnect the new couplings two or three times to work the PTFE seals. Sometimes a new coupling will stick if the seal has not been worked.
- When connecting the couplings, only apply the spanner or grips to the hexagon and nowhere else.
- Avoid damage to the coupling faces. Burrs and scratches cause damage to the seals and cause leaks. They can also impede connection and disconnection of the couplings.
- Periodically lubricate the internal locking balls on the female half of the coupling with silicone grease.

### Essential don'ts:

- Never try to reconnect using a damaged half coupling as this will destroy the seals in the mating half and necessitate replacement of both halves.
- Do not leave the coupling where it may be run over by a machine or otherwise crushed, this will distort the sleeve and prevent connection and disconnection.
- Never try to turn the sleeve when the coupling is disconnected as this will cause the locking ball to jam under the locking sleeve and damage the coupling.
- Never try to strip the coupling down, there are no user serviceable parts. If the coupling is damaged it must be replaced with a new one.
- Never hit the centre poppet of the coupling to try and release the locked in pressure. This can cause irreparable damage to the coupling and serious injury.
- When connecting the couplings, never clamp on the sleeve of the female or nose of the male, this will cause distortion and/or damage.
- Never subject the couplings to external forces, especially side load. This can decrease the life of the coupling or cause failure.

- Never allow the torsional forces transmitted from the hoses to unscrew/screw together the couplings.
- Never use a coupling as a plug.
- Do not connect and disconnect with pressure in the line unless the coupling type is specifically designed to do so.

### Connecting Quick Release Couplings

1. Remove any residual hydraulic pressure trapped in the service line hose.
2. Wipe the two faces of the male and female couplings and make sure they are clean.
3. Make sure that ball in the female coupling is located in one of its slots.
4. Connect the male coupling into the female coupling.
5. Where applicable, rotate the sleeve half a turn and make sure that the locking ball does not align with the slot.

**Figure 46.**

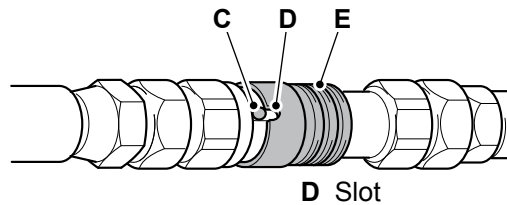

- C** Ball  
**E** Sleeve

### Disconnecting Quick Release Couplings

1. Remove any residual hydraulic pressure trapped in the service line hose.
2. Where applicable, align the slot with ball.
3. Pull back the sleeve to release the coupling.

## Oil

### Check (Level)

1. Make the machine safe with the platform lowered.  
[Refer to: Maintenance Positions \(Page 58\).](#)
2. Look at the hydraulic fluid in the sight hole. If the hydraulic fluid is cloudy, water or air is the system. Water or air in the system can damage the hydraulic pump. Contact your JCB dealer if the hydraulic fluid is cloudy.  
[Refer to: Service Points \(Page 61\).](#)
3. If necessary, add the recommended hydraulic fluid.
  - 3.1. Open the hydraulic filler cap.
  - 3.2. Use a suitable container to add the hydraulic fluid through the filler port.
  - 3.3. Check the level of hydraulic fluid.
  - 3.4. Close the filler cap.

# Electrical System

## General

### Check (Operation)

Make sure all of the electrical equipment operates correctly, for example:

- Switches
- Warning lights
- Beacon
- Alarms
- Horn
- Hourmeter/display
- Battery
- Lights

All defective equipment must be repaired before the machine is used.

### Check (Condition)

For: Lead Acid Battery ..... Page 75

(For: Lead Acid Battery)

**▲ WARNING** Battery electrolyte is toxic and corrosive. Do not breathe the gases given off by the battery. Keep the electrolyte away from your clothes, skin, mouth and eyes. Wear safety glasses.

**DANGER** Batteries give off explosive gases. Keep flames and sparks away from the battery. Do not smoke close to the battery. Make sure there is good ventilation in closed areas where batteries are being used or charged. Do not check the battery charge by shorting the terminals with metal. Use a hydrometer or voltmeter.

**CAUTION** Understand the electrical circuit before connecting or disconnecting an electrical component. A wrong connection can cause injury and/or damage.

Examine the electrical circuits regularly for:

- Damaged connectors
- Loose connections
- Chafing on the wiring harnesses
- Corrosion
- Missing insulation
- Incorrect routing of the wiring harnesses
- Insulation covers on battery terminals and leads

Do not use the machine if one or more of these faults are found. You must make sure that the electrical circuit is repaired immediately.

## Battery

### Clean

For: Lead Acid Battery ..... Page 75

(For: Lead Acid Battery)

**▲ WARNING** Keep metal watch straps and any metal fasteners on your clothes, clear of the positive (+) battery terminal. Such items can short between the terminal and nearby metal work. If it happens you can get burned.

1. Make the machine safe.

[Refer to: Maintenance Positions \(Page 58\).](#)

2. Get access to the battery.  
[Refer to: Access Apertures \(Page 63\).](#)
3. If the terminal posts are corroded and covered with white powder wash them with hot water. If there is considerable corrosion, clean the terminal posts with a wire brush or abrasive paper. Refer to Figure 47.

Figure 47.

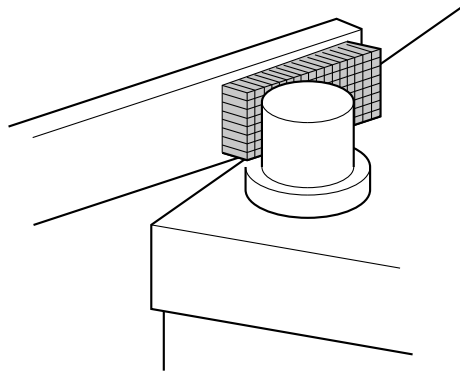

4. Apply a thin layer of petroleum jelly to the terminal posts.

### Connect

- ▲ **CAUTION** The machine is negatively earthed. Always connect the negative pole of the battery to earth.  
When connecting the battery, connect the earth (-) lead last.  
When disconnecting the battery, disconnect the earth (-) lead first.

1. Get access to the batteries.  
[Refer to: Disconnect \(Page 76\).](#)
2. Make sure that the terminal covers are fitted except exposed terminal posts.
3. Connect the battery leads. Connect the earth (-) terminal last.
4. If the machine has a battery isolator key, then connect the isolator.  
[Refer to: Battery Isolator \(Page 22\).](#)

### Disconnect

- ▲ **WARNING** Do not use batteries lighter than the original ones. The batteries work as counterweight and are critical to the stability of machine.
- WARNING** Do not use the machine with the counterweights removed. The counterweights are critical to the stability of machine.
- CAUTION** Batteries are heavy. Use an appropriate number of people to lift the batteries. Use appropriate lifting techniques.
- CAUTION** The machine is negatively earthed. Always connect the negative pole of the battery to earth.  
When connecting the battery, connect the earth (-) lead last.  
When disconnecting the battery, disconnect the earth (-) lead first.
- Notice:** Do not isolate the machine electrics when the machine is in operation, this may cause damage to the machine electrics.

1. Make the machine safe.  
[Refer to: Maintenance Positions \(Page 58\).](#)
2. Get access to the batteries.

Refer to: Access Apertures (Page 63).

- If the machine has a battery isolator, then disconnect the battery isolator.

Refer to: Battery Isolator (Page 22).

- Disconnect the battery leads. Disconnect the earth (-) terminal first.

### Check (Electrolyte Level)

For: Lead Acid Battery ..... Page 77

(For: Lead Acid Battery)

**▲ WARNING** Do not top the battery up with acid. The electrolyte could boil out and burn you.

- Make the machine safe.
- Open the battery compartment cover.
- Remove the vent caps.
- Check the electrolyte level.
  - The minimum level is at the top of the plates.
  - If necessary, add just enough distilled water to cover the plates at this time.
- Install the vent caps.
- Put batteries on a complete charge before adding any additional distilled water.
- Remove the vent caps.
- Add distilled water until the electrolyte level is below the bottom of the fill well by the specified value.  
Distance: 3.175mm
  - If necessary, use a piece of rubber as a dipstick to determine this level.

Figure 48.

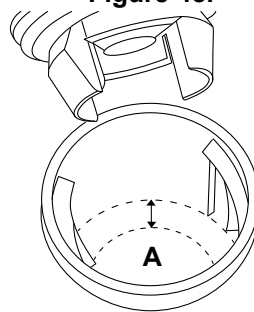

**A** Electrolyte level (3.175mm)

- Clean the vent caps.
- Install the vent caps.

### Check (Charge Level)

**▲ WARNING** Do not connect the charger when the batteries are not connected. Doing so could result in danger of live terminals from the charger.

Do not carry out maintenance on a machine whilst the charger is connected to an external power supply (i.e. do not work on a live machine). Cables from the charger to the batteries may remain live even if the batteries are disconnected/removed from the machine. There is a risk of serious electrical shock.

Always disconnect all external power supplies to the machine before carrying out maintenance.

The battery should be checked when the motor is running, this will avoid mis-reading the charge level because of battery voltage recovery due to lack of current draw.



An approximate charge level of the battery is shown on the platform controller and battery charger display.

When the level of batteries is about 20%, the battery must be charged. Never let the battery fully discharge before charging.

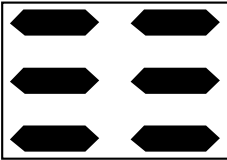
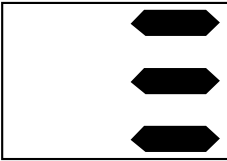
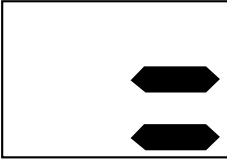

When the battery voltage is low, select low speed mode and drive at low speed / half throttle to a charge location.

For machines with Lithium Iron Phosphate Batteries; If the machine is driven on low battery level for too long, the battery management system will cut off the electrical supply from the batteries, to protect the batteries from too deep a discharge. Restarting the machine will have no effect. The machine will be non-operational until the charger is connected to an external power supply.

**Table 11. Platform Control Display**

	Fully charged
	30%
	Charge battery now
	Battery too low - charge battery now

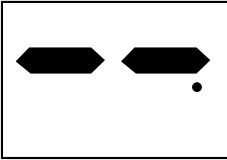
**Table 12. Ground Control Display**

	Operational
	Not operational

**Charge the Battery**

When charging the batteries, refer to the battery charger display to view the charge status of the batteries. Refer to Figure 49.

Figure 49.

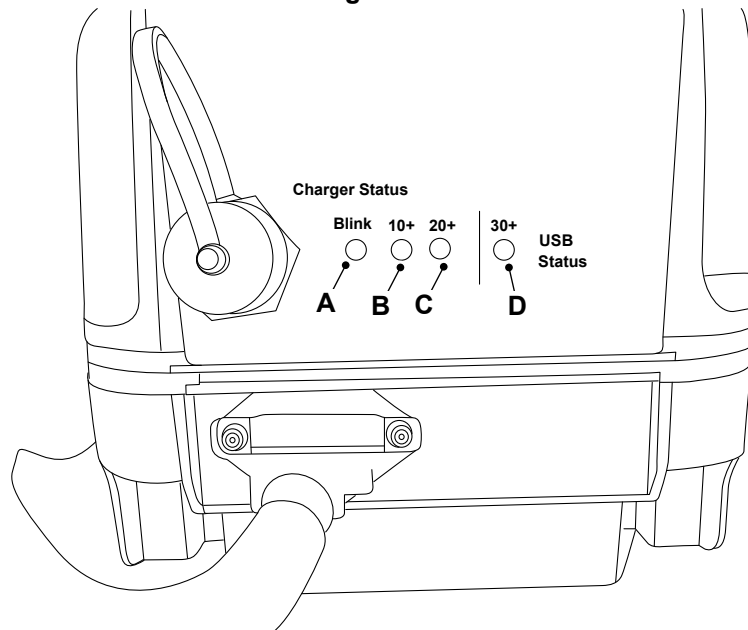

A 50%  
C 100%

B 70%  
D USB (Universal Serial Bus) status

Only use the original charger installed to the machine with the original batteries. Charge the battery in a well ventilated place. Use an appropriate grounded industrial power supply with the correct AC (Alternating Current) input voltage to charge.

1. Make sure the battery is properly connected before charging. Check the terminal connections are tight.
2. Remove the ventilation cap and check the electrolyte level is above the polar plate. Replenish with distilled water if required. Do not overfill. Install the ventilation cap.
3. Connect the charger to the AC supply. Refer to Figure 50.

Figure 50.

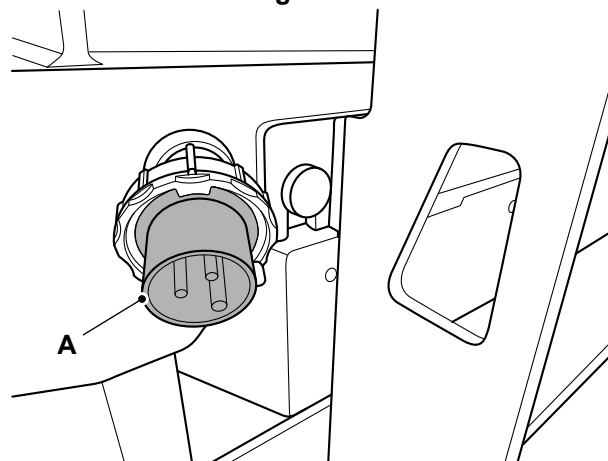

A Battery charging socket

Battery and power to platform connectors may be mounted rigidly in the mounting holes or hung loose with their cables according to operator preference.

### Fault Indicator

When a fault occurs, all three battery charge indicator LED (Light Emitting Diode)'s will blink at the same time. Refer to Table 13.

**Table 13.**

Blink- ing Fre- quency	Cause	Remedy
1	The battery is not connected or the battery voltage is too low	No charging at the time or the battery voltage is less than 4V.
2	Abnormal AC Power Input (Voltage)	Check AC input cord is connected between charger and AC outlet. Make sure AC plug is tightly secured into the AC outlet.
3	Charger High Temperature Protection	Charger shuts down and goes into protection mode due to charger / environmental temperature too high for charger to function properly. Place the charger into an area with ambient air flow or to a cooler place. Disconnect the charger and wait for 15–20min before reconnecting it for charging.
4	Battery High Temperature Protection	Charger will reduce or even stop charging when the battery temperature exceeds 50°C (121.9°F). This is to protect the battery from overheating. Disconnect the charger and wait for 15–20min before reconnecting it for charging.
5	Output Current is too large	Contact JCB dealer for repair.
6	Battery Voltage is too high (>28.5V)	Check and make sure that the correct output battery voltage is connected.
7	Battery Voltage is too low (<17.5V)	Check and make sure that the correct output battery voltage is connected. (The charger keeps charging normally even though the battery voltage is more than 4V.)

## Battery Isolator

### Check (Operation)

**▲ Notice:** Do not isolate the machine electrics when the machine is in operation, this may cause damage to the machine electrics.

1. Isolate the machine electrics.
2. Make sure that the machine electrics are isolated.

A defective isolator must be repaired before the machine is used. For more information, contact your JCB dealer.

## Fuses

### Replace

The electrical circuits are protected by fuses. If a fuse blows, find out why before a new one is installed.

#### Primary Fuses

The primary fuses are located in the battery compartment. [Refer to: General \(Page 61\)](#).

#### Secondary Fuses

The secondary fuses are located in the hydraulic compartment. [Refer to: General \(Page 61\)](#).



## Relays

### Replace

The relays are situated in the hydraulic compartment. [Refer to: General \(Page 61\)](#).



---

Notes:

---

---

---

---

---

---

---

---

---

---

---

# Technical Data

## Introduction

### General

All the rated operating capacities/rated lift capacities are based on the criteria of the machine being level on a firm supporting ground and wind speed is below the specified limit.

## Static Dimensions

### Dimensions

For: S1530E .....	Page 84
For: S1930E .....	Page 84
For: S2032E .....	Page 84
For: S2046E .....	Page 85
For: S2632E .....	Page 85
For: S2646E .....	Page 85
For: S3246E .....	Page 86
For: S4046E .....	Page 86
For: S4550E .....	Page 86

(For: S1530E)

Table 14.

Description	Dimension
Maximum platform height	4.6m
Maximum working height	6.6m
Platform size (L x W x H)	1.64m x 0.76m x 1.1m
Ground clearance	0.07m
Wheelbase	1.33m
Extension outreach	0.9m
Overall length (stowed)	1.78m
Overall width (stowed)	0.76m
Overall height (stowed, guardrail folded)	1.84m
Overall height (stowed, guardrail unfolded)	2.1m

(For: S1930E)

Table 15.

Description	Dimension
Maximum platform height	5.8m (19' 0")
Maximum working height	7.8m (25' 7")
Platform size (L x W x H)	1.64m x 0.76m x 1.1m
Ground clearance	0.07m
Wheelbase	1.53m
Extension outreach	0.9m
Overall length (stowed)	1.78m
Overall width (stowed)	0.76m
Overall height (stowed, guardrail folded)	1.86m (6' 1")
Overall height (stowed, guardrail unfolded)	2.11m (6' 11")

(For: S2032E)

Table 16.

Description	Dimension
Maximum platform height	6.3m (20' 8")
Maximum working height	8.3m (27' 2")
Platform size (L x W x H)	2.25m x 0.81m x 1.1m
Ground clearance	0.1m
Wheelbase	1.85m
Extension outreach	0.9m

Description	Dimension
Overall length (stowed)	2.39m
Overall width (stowed)	0.81m
Overall height (stowed, guardrail folded)	1.83m (6' 0")
Overall height (stowed, guardrail unfolded)	2.22m (7' 3")

(For: S2046E)

**Table 17.**

Description	Dimension
Maximum platform height	6.3m (20' 8")
Maximum working height	8.3m (27' 2")
Platform size (L x W x H)	2.25m x 1.15m x 1.1m
Ground clearance	0.1m
Wheelbase	1.85m
Extension outreach	0.9m
Overall length (stowed)	2.39m
Overall width (stowed)	1.15m
Overall height (stowed, guardrail folded)	1.83m (6' 0")
Overall height (stowed, guardrail unfolded)	2.22m (7' 3")

(For: S2632E)

**Table 18.**

Description	Dimension
Maximum platform height	8.1m (26' 6")
Maximum working height	10.1m (33' 1")
Platform size (L x W x H)	2.25m x 0.81m x 1.1m
Ground clearance	0.1m
Wheelbase	1.85m
Extension outreach	0.9m
Overall length (stowed)	2.39m
Overall width (stowed)	0.81m
Overall height (stowed, guardrail folded)	1.96m (6' 5")
Overall height (stowed, guardrail unfolded)	2.35m (7' 8")

(For: S2646E)

**Table 19.**

Description	Dimension
Maximum platform height	8.1m (26' 6")
Maximum working height	10.1m (33' 1")
Platform size (L x W x H)	2.25m x 1.15m x 1.1m
Ground clearance	0.1m
Wheelbase	1.85m
Extension outreach	0.9m
Overall length (stowed)	2.39m
Overall width (stowed)	1.15m
Overall height (stowed, guardrail folded)	1.96m (6' 5")
Overall height (stowed, guardrail unfolded)	2.35m (7' 8")

(For: S3246E)

**Table 20.**

Description	Dimension
Maximum platform height	10m (32' 9")
Maximum working height	12m (39' 4")
Platform size (L x W x H)	2.25m x 1.15m x 1.1m
Ground clearance	0.1m
Wheelbase	1.85m
Extension outreach	0.9m
Overall length (stowed)	2.39m
Overall width (stowed)	1.15m
Overall height (stowed, guardrail folded)	1.86m (6' 1")
Overall height (stowed, guardrail unfolded)	2.48m (8' 1")

(For: S4046E)

**Table 21.**

Description	Dimension
Maximum platform height	11.9m (39' 0")
Maximum working height	13.9m (45' 7")
Platform size (L x W x H)	2.25m x 1.15m x 1.1m
Ground clearance	0.1m
Wheelbase	1.85m
Extension outreach	0.9m
Overall length (stowed)	2.39m
Overall width (stowed)	1.15m
Overall height (stowed, guardrail folded)	1.98m (6' 5")
Overall height (stowed, guardrail unfolded)	2.60m (8' 6")

(For: S4550E)

**Table 22.**

Description	Dimension
Maximum platform height	13.8m (45' 3")
Maximum working height	15.8m (51' 10")
Platform size (L x W x H)	2.64m x 0.81m x 1.1m
Ground clearance	0.1m
Wheelbase	2.22m
Extension outreach	0.9m
Overall length (stowed)	2.76m
Overall width (stowed)	1.25m
Overall height (stowed, guardrail folded)	2.20m (7' 2")
Overall height (stowed, guardrail unfolded)	2.60m (8' 6")

## Weights

For: S1530E .....	Page 87
For: S1930E .....	Page 87
For: S2032E .....	Page 87
For: S2046E .....	Page 88
For: S2632E .....	Page 88
For: S2646E .....	Page 88
For: S3246E .....	Page 88
For: S4046E .....	Page 89
For: S4550E .....	Page 89

(For: S1530E)

**Table 23.**

Description	Dimension
Overall weight	1,330kg
Load capacity	280kg
Maximum platform occupants (indoor)	2 persons
Maximum platform occupants (outdoor)	1 person
Maximum allowable side force (indoor)	400N
Maximum allowable side force (outdoor)	200N
Maximum wheel loads	550kg

(For: S1930E)

**Table 24.**

Description	Dimension
Overall weight	1,526kg
Load capacity	230kg
Maximum platform occupants (indoor)	2 persons
Maximum platform occupants (outdoor)	1 person
Maximum allowable side force (indoor)	400N
Maximum allowable side force (outdoor)	200N
Maximum wheel loads	550kg

(For: S2032E)

**Table 25.**

Description	Dimension
Overall weight	1,834kg
Load capacity	380kg
Maximum platform occupants (indoor)	2 persons
Maximum platform occupants (outdoor)	1 person
Maximum allowable side force (indoor)	400N
Maximum allowable side force (outdoor)	200N
Maximum wheel loads	980kg

(For: S2046E)

**Table 26.**

<b>Description</b>	<b>Dimension</b>
Overall weight	2,134kg
Load capacity	550kg
Maximum platform occupants (indoor)	2 persons
Maximum platform occupants (outdoor)	2 persons
Maximum allowable side force (indoor)	400N
Maximum allowable side force (outdoor)	400N
Maximum wheel loads	1,180kg

(For: S2632E)

**Table 27.**

<b>Description</b>	<b>Dimension</b>
Overall weight	1,972kg
Load capacity	250kg
Maximum platform occupants (indoor)	2 persons
Maximum platform occupants (outdoor)	N/A
Maximum allowable side force (indoor)	400N
Maximum allowable side force (outdoor)	N/A
Maximum wheel loads	1,080kg

(For: S2646E)

**Table 28.**

<b>Description</b>	<b>Dimension</b>
Overall weight	2,528kg
Load capacity	450kg
Maximum platform occupants (indoor)	2 persons
Maximum platform occupants (outdoor)	2 persons
Maximum allowable side force (indoor)	400N
Maximum allowable side force (outdoor)	400N
Maximum wheel loads	1,390kg

(For: S3246E)

**Table 29.**

<b>Description</b>	<b>Dimension</b>
Overall weight	2,646kg
Load capacity	320kg
Maximum platform occupants (indoor)	2 persons
Maximum platform occupants (outdoor)	1 person
Maximum allowable side force (indoor)	400N
Maximum allowable side force (outdoor)	200N
Maximum wheel loads	1,180kg



(For: S4046E)

**Table 30.**

<b>Description</b>	<b>Dimension</b>
Overall weight	2,996kg
Load capacity	320kg
Maximum platform occupants (indoor)	2 persons
Maximum platform occupants (outdoor)	1 person
Maximum allowable side force (indoor)	400N
Maximum allowable side force (outdoor)	200N
Maximum wheel loads	1,180kg

(For: S4550E)

**Table 31.**

<b>Description</b>	<b>Dimension</b>
Overall weight	3,366kg
Load capacity	227kg
Maximum platform occupants (indoor)	2 persons
Maximum platform occupants (outdoor)	N/A
Maximum allowable side force (indoor)	400N
Maximum allowable side force (outdoor)	N/A
Maximum wheel loads	1,140kg

## Performance Dimensions

### Driving Performance

For: S1530E .....	Page 90
For: S1930E .....	Page 90
For: S2032E .....	Page 91
For: S2046E .....	Page 91
For: S2632E .....	Page 91
For: S2646E .....	Page 92
For: S3246E .....	Page 92
For: S4046E .....	Page 92
For: S4550E .....	Page 93

(For: S1530E)

**Table 32.**

Description	Dimension
Maximum allowable wind speed (outdoor)	12.5m/s (1 person only)
Maximum allowable slope (front/back)	3°
Maximum allowable slope (side/side)	1.5°
Turning radius (outside)	1.49m
Turning radius (inside)	0.04m
Gradeability	30%
Maximum driving speed - platform raised /time over 10m	0.8km/h (0.5mph) /45s
Hare speed /time over 10m	3.2km/h (2.0mph) /(11s
Tortoise speed /time over 10m	1.8km/h (1.1mph) /20s
Rising speed (loaded)	15–20s
Lowering speed (loaded)	28–33s
Drive and steer model	2, front-wheel
Brake	2 rear-wheel

(For: S1930E)

**Table 33.**

Description	Dimension
Maximum allowable wind speed (outdoor)	12.5m/s (1 person only)
Maximum allowable slope (front/back)	3°
Maximum allowable slope (side/side)	1.5°
Turning radius (outside)	1.49m
Turning radius (inside)	0.04m
Gradeability	25%
Maximum driving speed - platform raised /time over 10m	0.8km/h (0.5mph) /45s
Hare speed /time over 10m	3.2km/h (2.0mph) /11s
Tortoise speed /time over 10m	1.8km/h (1.1mph) /20s
Rising speed (loaded)	15–20s
Lowering speed (loaded)	25–30s
Drive and steer model	2, front-wheel
Brake	2 rear-wheel

(For: S2032E)

**Table 34.**

<b>Description</b>	<b>Dimension</b>
Maximum allowable wind speed (outdoor)	12.5m/s (1 person only)
Maximum allowable slope (front/back)	3°
Maximum allowable slope (side/side)	1.5°
Turning radius (outside)	2.1m
Turning radius (inside)	0m
Gradeability	30%
Maximum driving speed - platform raised /time over 10m	0.8km/h (0.5mph) /45s
Hare speed /time over 10m	3.2km/h (2.0mph) /11s
Tortoise speed /time over 10m	1.8km/h (1.1mph) /20s
Rising speed (loaded)	25–30s
Lowering speed (loaded)	30–35s
Drive and steer model	2, front-wheel
Brake	2 rear-wheel

(For: S2046E)

**Table 35.**

<b>Description</b>	<b>Dimension</b>
Maximum allowable wind speed (outdoor)	12.5m/s
Maximum allowable slope (front/back)	3°
Maximum allowable slope (side/side)	1.5°
Turning radius (outside)	2.35m
Turning radius (inside)	0m
Gradeability	25%
Maximum driving speed - platform raised /time over 10m	0.8km/h (0.5mph) /45s
Hare speed /time over 10m	3.2km/h (2.0mph) /11s
Tortoise speed /time over 10m	1.8km/h (1.1mph) /20s
Rising speed (loaded)	25–30s
Lowering speed (loaded)	30–35s
Drive and steer model	2, front-wheel
Brake	2 rear-wheel

(For: S2632E)

**Table 36.**

<b>Description</b>	<b>Dimension</b>
Maximum allowable wind speed (outdoor)	0m/s (Indoor only)
Maximum allowable slope (front/back)	3°
Maximum allowable slope (side/side)	1.5°
Turning radius (outside)	2.1m
Turning radius (inside)	0m
Gradeability	25%
Maximum driving speed - platform raised /time over 10m	0.8km/h (0.5mph) /45s
Hare speed /time over 10m	3.2km/h (2.0mph) /11s
Tortoise speed /time over 10m	1.8km/h (1.1mph) /20s

Description	Dimension
Rising speed (loaded)	30–35s
Lowering speed (loaded)	35–40s
Drive and steer model	2, front-wheel
Brake	2 rear-wheel

(For: S2646E)

**Table 37.**

Description	Dimension
Maximum allowable wind speed (outdoor)	12.5m/s
Maximum allowable slope (front/back)	3°
Maximum allowable slope (side/side)	1.5°
Turning radius (outside)	2.35m
Turning radius (inside)	0m
Gradeability	25%
Maximum driving speed - platform raised /time over 10m	0.8km/h (0.5mph) /45s
Hare speed /time over 10m	3.2km/h (2.0mph) /11s
Tortoise speed /time over 10m	1.8km/h (1.1mph) /20s
Rising speed (loaded)	30–35s
Lowering speed (loaded)	35–40s
Drive and steer model	2, front-wheel
Brake	2 rear-wheel

(For: S3246E)

**Table 38.**

Description	Dimension
Maximum allowable wind speed (outdoor)	12.5m/s (1 person only)
Maximum allowable slope (front/back)	3°
Maximum allowable slope (side/side)	1.5°
Turning radius (outside)	2.35m
Turning radius (inside)	0m
Gradeability	25%
Maximum driving speed - platform raised /time over 10m	0.8km/h (0.5mph) /45s
Hare speed /time over 10m	3.2km/h (2.0mph) /11s
Tortoise speed /time over 10m	1.8km/h (1.1mph) /20s
Rising speed (loaded)	53–58s
Lowering speed (loaded)	40–45s
Drive and steer model	2, front-wheel
Brake	2 rear-wheel

(For: S4046E)

**Table 39.**

Description	Dimension
Maximum allowable wind speed (outdoor)	12.5m/s (1 person only)
Maximum allowable slope (front/back)	3°
Maximum allowable slope (side/side)	1.5°

Description	Dimension
Turning radius (outside)	2.35m
Turning radius (inside)	0m
Gradeability	25%
Maximum driving speed - platform raised /time over 10m	0.8km/h (0.5mph) /45s
Hare speed /time over 10m	3km/h (1.9mph) /12s
Tortoise speed /time over 10m	1.6km/h (1.0mph) /22.5s
Rising speed (loaded)	63–68s
Lowering speed (loaded)	45–50s
Drive and steer model	2, front-wheel
Brake	2 rear-wheel

(For: S4550E)

**Table 40.**

Description	Dimension
Maximum allowable wind speed (outdoor)	0m/s (Indoor only)
Maximum allowable slope (front/back)	3°
Maximum allowable slope (side/side)	1.5°
Turning radius (outside)	2.56m
Turning radius (inside)	0m
Gradeability	25%
Maximum driving speed - platform raised /time over 10m	0.8km/h (0.5mph) /45s
Hare speed /time over 10m	3km/h (1.9mph) /12s
Tortoise speed /time over 10m	1.6km/h (1.0mph) /22.5s
Rising speed (loaded)	75–85s
Lowering speed (loaded)	55–63s
Drive and steer model	2, front-wheel
Brake	2 rear-wheel



## Noise Emissions

### Noise Data

#### All Machines

Noise value does not exceed 70dB.

## Vibration Emissions

### Vibration Data

Whole-body vibration emission determined in accordance with ISO 2631-1:1997 does not exceed 0.5m/s.

Hand-arm vibration determined in accordance with dynamic test conditions defined in ISO 5349-2: 2001 does not exceed 2.5m/s.



## Fluids, Lubricants and Capacities

### General

JCB recommend that you use the JCB lubricants shown as they have been verified by JCB for use on JCB machines. However, you could use other lubricants that are equivalent to the JCB standards and quality or offer the same machine component protection.

Table 41.

Item	Capacity	Fluid/Lubricant	JCB Part Number	Container Size <sup>(1)</sup>	Specification
Hydraulic system	18–25L	JCB optimum performance hydraulic fluid	4002/2005	20L	
Grease points	-	JCB special HP grease	4003/2017	0.4kg	
Electrical connections	-	As a corrosion and moisture inhibitor all exposed connections should be coated liberally with petroleum jelly	-	-	

*(1) For information about the different container sizes that are available (and their part numbers), contact your JCB dealer.*



## Electrical System

### General

For: Lead Acid Battery ..... Page 97

For: Lithium Iron Phosphate Battery ..... Page 97

(For: Lead Acid Battery)

Table 42.

	S1530E	S1930E	S2032E	S2046E	S2632E
Lead acid batteries	T105, 225AH	T105, 225AH	T105, 225AH	T105, 225AH	T105, 225AH
Specification	24V DC - 4x 6V	24V DC - 4x 6V	24V DC - 4x 6V	24V DC - 4x 6V	24V DC - 4x 6V

Table 43.

	S2646E	S3246E	S4046E	S4550E
Lead acid batteries	T105,225AH	T125,240AH	T1275	T1275
Specification	24V DC - 4x 6V	24V DC - 4x 6V	24V DC - 4x12V	24V DC - 4x12V

(For: Lithium Iron Phosphate Battery)

Table 44.

	S1530E	S1930E	S2032E	S2046E	S2632E	S2646E
Lithium Iron batteries	LFP Smart 12,8/90	LFP Smart 12,8/90	LFP Smart 12,8/90	LFP Smart 12,8/90	LFP Smart 12,8/90	LFP Smart 12,8/90
Specification	24V DC - 2x 12V 90Ah	24V DC - 2x 12V 90Ah	24V DC - 2x 12V 90Ah	24V DC - 2x 12V 90Ah	24V DC - 2x 12V 90Ah	24V DC - 4x 6V

### Fuses

#### Primary Fuses

Table 45.

Fuse	Rating
Primary fuse (high rating)	275A
Primary fuse- single inline (low rating)	20A

#### Secondary Fuses

Figure 51.

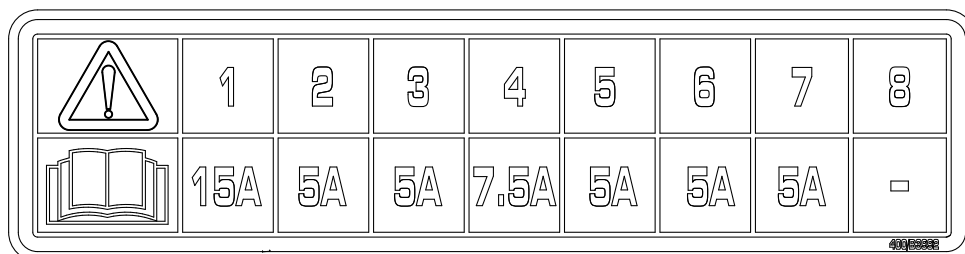

Table 46.

Fuse	Circuit	Rating
1	Permanent feed - ignition relay contact	15A
2	Permanent Feed - livelink permanent (Option)	5A

<b>Fuse</b>	<b>Circuit</b>	<b>Rating</b>
3	Permanent feed - emergency stop, charger switch, ignition key, Up/Down switch, platform controller	5A
4	Ignition feed - main ECU controller, hour meter feed, motor controller	7.5A
5	Ignition Feed - lower limit, Tilt switch, angle sensor, pressure sensor 1, pothole switch 2 (right hand) separate input	5A
6	Lower limit switch input 2, upper limit switch, pressure sensor 2, left hand/right hand pothole series connection	5A
7	Livelink ignition feed (option), ground alarm	5A
8	Spare	-

## Hydraulic System

### General

For: S1530E, S1930E, S2032E, S2046E, S2632E, S2646E ..... Page 99  
For: S3246E, S4046E ..... Page 99  
For: S4550E ..... Page 99

(For: S1530E, S1930E, S2032E, S2046E, S2632E, S2646E)

**Table 47.**

Hydraulic oil tank volume	14L
Hydraulic system tank volume	18L
Hydraulic system pressure	240bar (3,478.2psi)

(For: S3246E, S4046E)

**Table 48.**

Hydraulic oil tank volume	14L
Hydraulic system tank volume	22L
Hydraulic system pressure	240bar (3,478.2psi)

(For: S4550E)

**Table 49.**

Hydraulic oil tank volume	14L
Hydraulic system tank volume	25L
Hydraulic system pressure	240bar (3,478.2psi)

## Wheels and Tyres

### General

Table 50.

Model	Solid Tyre Dimensions
S1530E	305mm x 115mm
S1930E	305mm x 115mm
S2032E	380mm x 125mm
S2046E	380mm x 125mm
S2632E	380mm x 125mm
S2646E	380mm x 125mm
S3246E	380mm x 125mm
S4046E	380mm x 125mm
S4550E	380mm x 125mm

## Fault-Finding

### General

#### Diagnostic Trouble Codes (DTC)

Error codes can be displayed on platform control display as well as on the ground control display.

When an alarm sounds the relevant error code will be displayed on the display.

Table 51.

Display	Description	Lift Reaction	Operator Instructions
01	System initialization fault	Disables all motion	Restart the machine
02	System communication Fault	Disables all motion	Restart the machine
03	Invalid option setting Fault	Disables all motion	Restart the machine
04	Load sensing data fault	Warning only	Contact JCB Dealer
12	Chassis up or down switch ON at power-up fault	Disables chassis control	Contact JCB Dealer
18	Pothole guard fault	Disable lifting and driving	Check the pothole protection plates have fully deployed
31	Pressure sensor 1 fault	Disables all motion	Contact JCB Dealer
32	Angle sensor fault	Disables all motion	Restart the machine
36	Limp mode	Lift slow to elevated speed	Check the batteries are fully charged
42	Platform left turn switch ON at power-up message	Diagnostic message only	Contact JCB Dealer
43	Platform right turn switch ON at power-up message	Diagnostic message only	Contact JCB Dealer
46	Platform joystick enable Switch ON at power-up fault	Disables platform control	Contact JCB Dealer
47	Platform joystick not in neutral at power-up message	Diagnostic message only	Restart the machine
52	Drive forward coil fault	Disables lifting and driving	Check that no controls are operated at start-up
53	Drive reverse coil fault	Disables lifting and driving	Contact JCB Dealer
54	Lift Up coil fault	Disables lifting and driving	Contact JCB Dealer
55	Lift Down coil fault	Disables lifting and driving	Contact JCB Dealer
56	Right Turn coil fault	Disable lifting and driving	Contact JCB Dealer
57	Left Turn Coil fault	Disables lifting and driving	Contact JCB Dealer
58	General brake coil fault	Disable lifting and driving	Contact JCB Dealer
59	Parallel coil fault	Disables lifting and driving	Contact JCB Dealer
60	Motor controller wiring Broken	Disable lifting and driving	Contact JCB Dealer
61	MC eeprom fault	Disables lifting and driving	Restart the machine
62	MC mosfet short fault	Disable lifting and driving	Contact JCB Dealer
64	MC Wiring fault	Disables lifting and driving	Contact JCB Dealer
68	Battery low voltage Fault	Disable all motion	Check the batteries are fully charged
69	MC throttle fault	Disables lifting and driving	Contact JCB Dealer
70	MC Main contactor Coil Short	Disable lifting and driving	Contact JCB Dealer
71	MC Main contactor Weld Fault	Disables lifting and driving	Restart the machine
72	MC main contactor driver fault	Disable lifting and driving	Contact JCB Dealer
77	MC over temperature cutoff	Disables lifting and driving	Contact JCB Dealer
80	Over 80% load warning	Warning only	Check the platform load
85	Pressure sensor 2 fault	Disables all motion	Contact JCB Dealer
86	Down limit switch fault	Disable all motion	Restart the machine

Display	Description	Lift Reaction	Operator Instructions
87	Up limit switch fault	Warning only	Contact JCB Dealer
90	Over 90% load warning	Warning only	Reduce weight from the platform
99	Over 99% load warning	Warning only	Reduce weight from the platform
OL	Overloaded platform fault	Disables all motion	Reduce weight from the platform, machine will not move till load reduced.
LL	Machine tilted beyond Safe limits fault	Disables lifting and driving	Check the ground level
LF	Up/down control fault	Warning only	Restart the machine

*(1) If any of the codes persist, connect the JCB ServiceMaster to fault find. Contact your JCB Dealer if required.*

If the machine reports an error on the display while driving with platform raised, lower the platform and move the machine to a smooth firm level surface. For more information, please contact your local JCB dealer.

In the event of an overload alarm 'OL', remove the excess load from the platform. Machine will not raise or lower until load is reduced.

## Declaration of Conformity

### General

A completed copy of the EC Declaration of Conformity is supplied with all machines manufactured according to EC type examination and/or self-certification requirements.

A sample copy of the EC Declaration of Conformity and a summary of the information that can appear is provided. [Refer to: Data \(Page 103\)](#).

### Data

Table 52.

A	<a href="#">Refer to: Name and Address of the Manufacturer (Page 5)</a> .
B	Mobile Elevating Work Platform
C	<a href="#">Refer to: Model and Serial Number (Page 1)</a> .
D	<a href="#">Refer to: Machine (Page 9)</a> .
E	Applicable standard
F	The Chief Engineer J.C. Bamford Access Limited, Rocester, Staffordshire, United Kingdom ST14 5JP
G	Notified Body Documentation
H	Place of Declaration
J	Date of Declaration
K	Position of Signatory

Figure 52.

<b>DECLARATION OF CONFORMITY</b>			
<p>NAME AND ADDRESS :</p>	<table border="1" style="width: 100%; border-collapse: collapse;"> <tr> <td style="padding: 2px;">JCB ACCESS LIMITED ROCESTER STAFFORDSHIRE UNITED KINGDOM ST14 5JP</td> <td style="text-align: center; vertical-align: middle;"><b>A</b></td> </tr> </table>	JCB ACCESS LIMITED ROCESTER STAFFORDSHIRE UNITED KINGDOM ST14 5JP	<b>A</b>
JCB ACCESS LIMITED ROCESTER STAFFORDSHIRE UNITED KINGDOM ST14 5JP	<b>A</b>		
<p>HEREBY DECLARES THAT THE MACHINERY / EQUIPMENT DESCRIBED BELOW: DESCRIPTION OF MACHINERY / EQUIPMENT:</p>	<table border="1" style="width: 100%; border-collapse: collapse;"> <tr> <td style="padding: 2px;">MOBILE ELEVATING WORK PLATFORM</td> <td style="text-align: center; vertical-align: middle;"><b>B</b></td> </tr> </table>	MOBILE ELEVATING WORK PLATFORM	<b>B</b>
MOBILE ELEVATING WORK PLATFORM	<b>B</b>		
<p>TRADE NAME:</p>	<table border="1" style="width: 100%; border-collapse: collapse;"> <tr> <td style="padding: 2px;">JCB</td> <td></td> </tr> </table>	JCB	
JCB			
<p>MODEL NAME:</p>	<table border="1" style="width: 100%; border-collapse: collapse;"> <tr> <td style="padding: 2px;"> </td> <td style="text-align: center; vertical-align: middle;"><b>C</b></td> </tr> </table>		<b>C</b>
	<b>C</b>		
<p>SERIAL NUMBER OF MACHINERY / EQUIPMENT</p>	<table border="1" style="width: 100%; border-collapse: collapse;"> <tr> <td style="padding: 2px;"> </td> <td style="text-align: center; vertical-align: middle;"><b>D</b></td> </tr> </table>		<b>D</b>
	<b>D</b>		
<p>COMPLIES WITH THE PROVISIONS OF THE "MACHINERY DIRECTIVE" (DIRECTIVE 2006/42/EC AS AMENDED).</p>			
<p>THE FOLLOWING STANDARDS HAVE BEEN USED:</p>	<table border="1" style="width: 100%; border-collapse: collapse;"> <tr> <td style="padding: 2px;">EN280</td> <td style="text-align: center; vertical-align: middle;"><b>E</b></td> </tr> </table>	EN280	<b>E</b>
EN280	<b>E</b>		
<p>NAME AND ADDRESS OF THE PERSON WHO COMPILES THE TECHNICAL DOCUMENTATION:</p>	<table border="1" style="width: 100%; border-collapse: collapse;"> <tr> <td style="padding: 2px;">THE CHIEF ENGINEER JCB ACCESS LTD ROCESTER, STAFFORDSHIRE ST14 5JP</td> <td style="text-align: center; vertical-align: middle;"><b>F</b></td> </tr> </table>	THE CHIEF ENGINEER JCB ACCESS LTD ROCESTER, STAFFORDSHIRE ST14 5JP	<b>F</b>
THE CHIEF ENGINEER JCB ACCESS LTD ROCESTER, STAFFORDSHIRE ST14 5JP	<b>F</b>		
<p>NOTIFIED BODY DOCUMENTATION:</p>	<table border="1" style="width: 100%; border-collapse: collapse;"> <tr> <td style="padding: 2px;">TÜV NORD CERT GMBH LANGEMARCKSTRASSE 20 45141 ESSEN GERMANY</td> <td style="text-align: center; vertical-align: middle;"><b>G</b></td> </tr> </table>	TÜV NORD CERT GMBH LANGEMARCKSTRASSE 20 45141 ESSEN GERMANY	<b>G</b>
TÜV NORD CERT GMBH LANGEMARCKSTRASSE 20 45141 ESSEN GERMANY	<b>G</b>		
<p>COMPLIES WITH THE PROVISIONS OF THE "ELECTRO-MAGNETIC COMPATIBILITY DIRECTIVE" (DIRECTIVE 2004/108/EEC AS AMENDED).</p>			
<p>COMPLIES WITH THE PROVISIONS OF THE "LOW VOLTAGE DIRECTIVE (DIRECTIVE 2006/95/EC AS AMENDED).</p>			
<p>TEST PRIOR TO PLACEMENT IN OPERATION T @ EN 280 CLAUSE 6.3:</p> <ol style="list-style-type: none"> <li>1. BRAKE S CORRECT OPERATION IN FORWARD AND REVERSE DIRECTION</li> <li>2. OVERLOAD @ LOADED TO 125% OF MAXIMUM RATED CAPACITY</li> <li>3. FUNCTION SMOOTH OPERATION TO 110% LOAD</li> </ol> <p style="margin-top: 10px;">GUARANTEED SOUND POWER LEVEL - LESS THAN 70DBA</p>			
<p>PLACE OF DECLARATION:</p>	<table border="1" style="width: 100%; border-collapse: collapse;"> <tr> <td style="padding: 2px;">ROCESTER</td> <td style="text-align: center; vertical-align: middle;"><b>H</b></td> </tr> </table>	ROCESTER	<b>H</b>
ROCESTER	<b>H</b>		
<p>DATE OF DECLARATION:</p>	<table border="1" style="width: 100%; border-collapse: collapse;"> <tr> <td style="padding: 2px;"> </td> <td style="text-align: center; vertical-align: middle;"><b>J</b></td> </tr> </table>		<b>J</b>
	<b>J</b>		
<p>NAME OF AUTHORISED SIGNATORY:</p>	<table border="1" style="width: 100%; border-collapse: collapse;"> <tr> <td style="padding: 2px;"> </td> <td></td> </tr> </table>		
<p>POSITION:</p>	<table border="1" style="width: 100%; border-collapse: collapse;"> <tr> <td style="padding: 2px;">MANAGING DIRECTOR</td> <td style="text-align: center; vertical-align: middle;"><b>K</b></td> </tr> </table>	MANAGING DIRECTOR	<b>K</b>
MANAGING DIRECTOR	<b>K</b>		
<p>SIGNATURE:</p>			
<p>English</p>			



## Warranty Information

### Service Record Sheet

Table 53.

	Signature and stamp		Date
	Annual Insurance (Yes)		Hours

Figure 53. Installation Checklist

			/ /		h

Figure 54. 1st 100h/1 Month

			/ /		h

Figure 55. 500h/6 Month

			/ /		h

Figure 56. 1000h/12 Month





 	 1 / /	 h
	-----	
	-----	
		

Figure 57. 1500h/18 Month



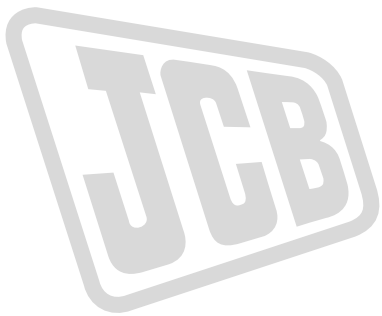

 	 1 / /	 h
	-----	
	-----	
		

Figure 58. 2000h/24 Month



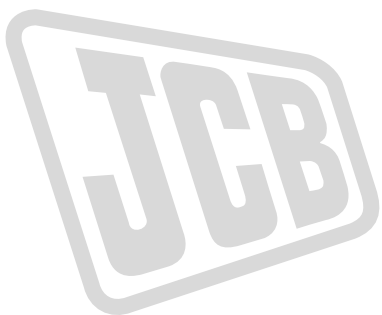

 	 1 / /	 h
	-----	
	-----	
		

Figure 59. 2500h/30 Month



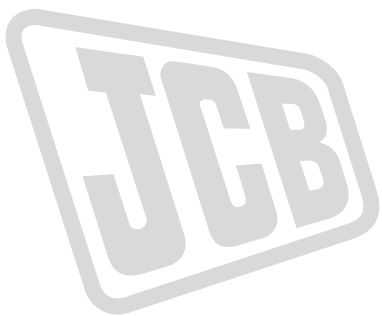

 	 1 / /	 h
	-----	
	-----	
		

Figure 60. 3000h/36 Month



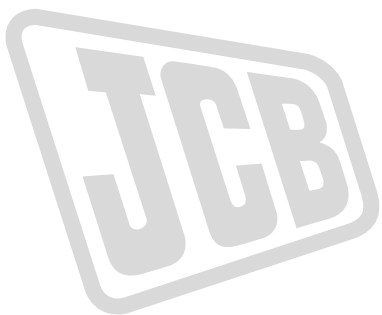

 	 1 / /	 h
	-----	
	-----	
		

Figure 61. 3500h/42 Month



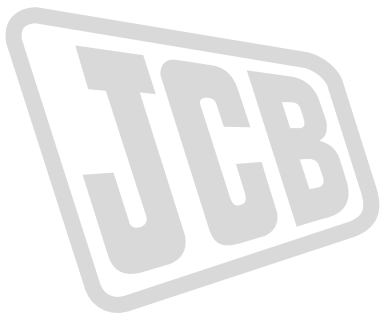

 	 1 / /	 h
	-----	
	-----	
		

Figure 62. 4000h/48 Month



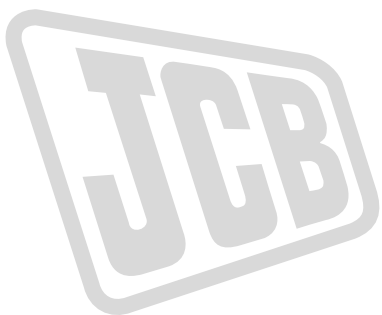

 	 1 / /	 h
	-----	
	-----	
		

Figure 63. 4500h/54 Month



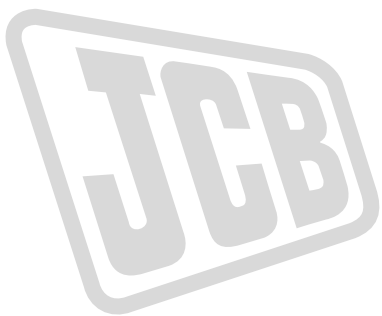

 	 1 / /	 h
	-----	
	-----	
		

Figure 64. 5000h/60Month



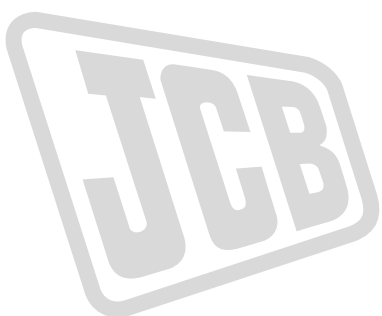

 	 1 / /	 h
	-----	
	-----	
		

Figure 65. 5500h/66 Month



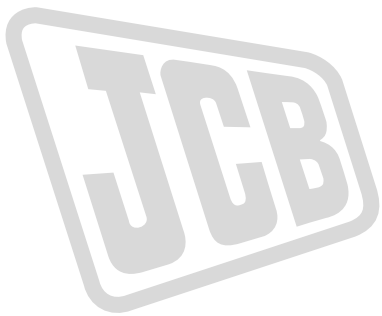

 	 1 / /	 h
	-----	
	-----	
		

Figure 66. 6000h/72 Month



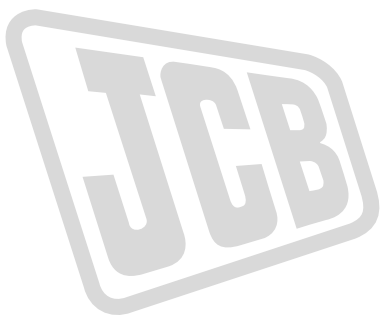

 	 1 / /	 h
	-----	
	-----	
		

Figure 67. 6500h/78 Month



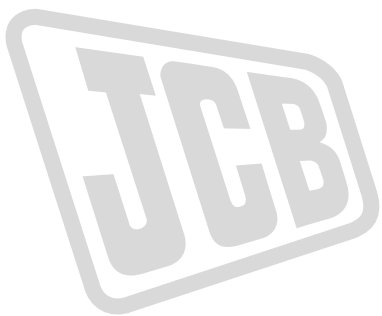

 	 1 / /	 h
	-----	
	-----	
		

Figure 68. 7000h/84 Month



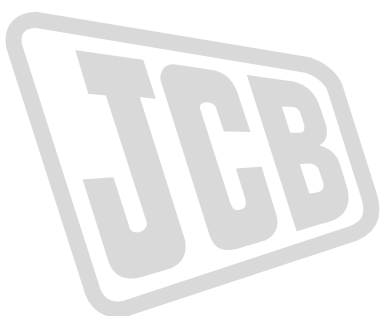

 	 1 / /		h
	-----		
	-----		
			

Figure 69. 7500h/90 Month



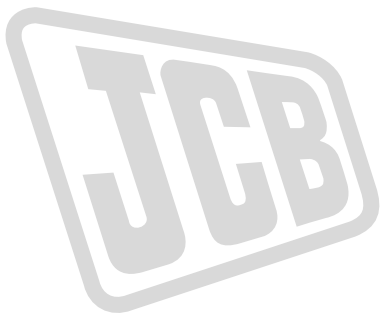

 	 1 / /		h
	-----		
	-----		
			

Figure 70. 8000h/96 Month



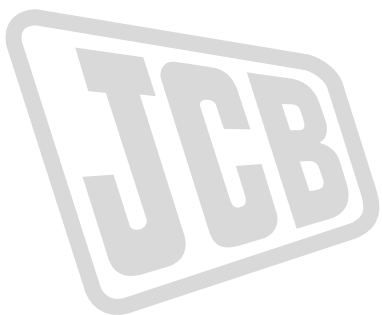

 	 1 / /		h
	-----		
	-----		
			

Figure 71. 8500h/102 Month



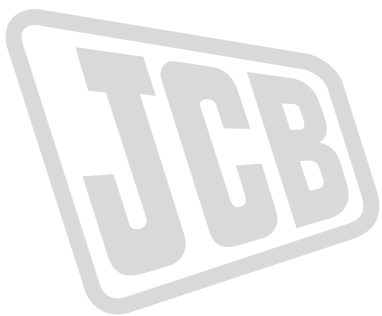

 	 1 / /		h
	-----		
	-----		
			

Figure 72. 9000h/108 Month



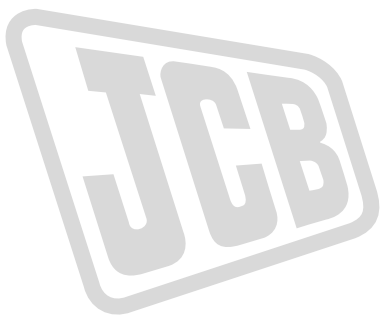

 	 1 / /	 h
	-----	
	-----	
		

Figure 73. 9500h/114 Month

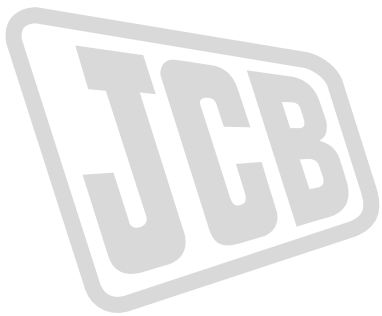

 	 1 / /	 h
	-----	
	-----	
	-----	

Figure 74. 10000h/120 Month



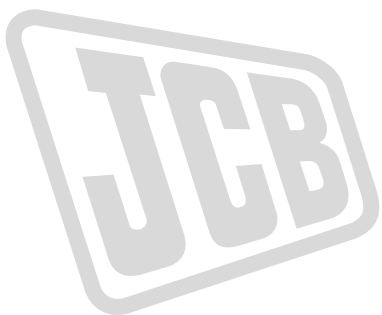

 	 1 / /	 h
	-----	
	-----	
		

Figure 75. 10500h/126 Month



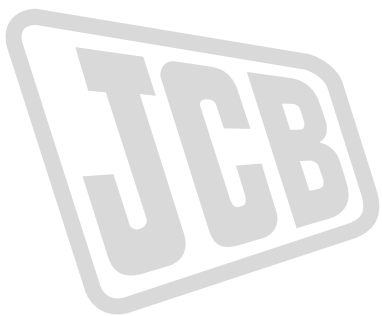



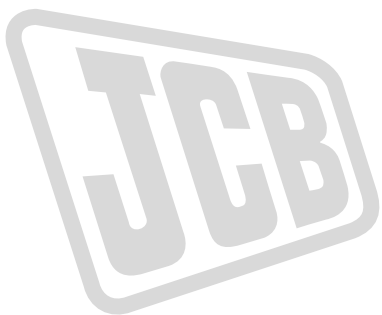

 	 1 / /	 h
	-----	
	-----	
	-----	

Figure 76. 11000h/132 Month

	 1 / /	 h
		
		



---

Notes:

---

---

---

---

---

---

---

---

---

---

---